

MADE IN ITALY
MADE IN VALDAMA



>valdama

VALDAMA, UN CUORE RICCO DI STORIA
PER UN FUTURO FATTO DI VALORI.

CI SONO REALTÀ AZIENDALI CHE NON HANNO BISOGNO DI LUNGHE PRESENTAZIONI, UN PRIVILEGIO CHE ACCOMUNA LE GRANDI IMPRESE MULTINAZIONALI ALLE AZIENDE DI CULTURA ARTIGIANA. LE PRIME INVESTONO QUANTITÀ COLOSSALI DI DENARO PER CONSEGUIRE NOTORIETÀ GLOBALE, LE SECONDE CONCENTRANO INVECE OGNI LORO RISORSA ECONOMICA E INTELLETTUALE NEL PROCESSO DI CREAZIONE DEI PRODOTTI.

VALDAMA APPARTIENE ALLA SECONDA CATEGORIA DI IMPRESE: QUELLE CHE CONCENTRANO NEI PENSIERI E NEI PRODOTTI L'IDEALE DELLA QUALITÀ ASSOLUTA, REALIZZANDO COSÌ OBIETTIVI CHE NON SONO MAI SCONTATI NÉ TANTOMENO IL FRUTTO DEL CASO. TUTTAVIA, RACCONTARE VALDAMA È SEMPLICE COME LA POETICA CHE ISPIRA I SUOI PRODOTTI. LA CULTURA AZIENDALE CHE INNERVA E SOSTANZIA OGNI SCELTA E OGNI PROGETTO HA QUALE RIFERIMENTO FONDAMENTALE LA RICERCA DELLA QUALITÀ. QUALITÀ ARTIGIANA DELL'AUTENTICO MADE IN ITALY, DALLE MATERIE PRIME ALLE MAESTRANZE CHE LE LAVORANO, UNA SCELTA DI POSIZIONAMENTO CHE CONSENTE A QUESTA AZIENDA DI TIRARSI FUORI DALLA MISCHIA DI UN MERCATO TROPPO SPESSO AVVILITO DA PRODOTTI STANDARDIZZATI SINO ALLA BANALIZZAZIONE. SEMPLICITÀ CHE, INUTILE RICORDARLO, NON È AFFATTO FACILE CONQUISTARE.

VALDAMA, A HEART FULL OF HISTORY
FOR A FUTURE OF VALUES.

SOME BUSINESSES DO NOT REQUIRE LENGTHY PRESENTATIONS: A PRIVILEGE SHARED BY THE LARGE MULTINATIONAL COMPANIES AND CRAFT-ORIENTED COMPANIES. THE FORMER INVEST COLOSSAL AMOUNTS OF MONEY TO ACHIEVE GLOBAL FAME, WHILE THE LATTER CONCENTRATE ALL THEIR RESOURCES IN THE ECONOMIC AND INTELLECTUAL PROCESS FOR CREATING PRODUCTS. VALDAMA BELONGS TO THE SECOND CATEGORY: IT FOCUSES ON IDEAS AND PRODUCTS SEEING THEM AS THE IDEAL OF ABSOLUTE QUALITY, THUS ACHIEVING GOALS THAT ARE NEVER FACILE NOR ACCIDENTAL. THIS IS TRUE SINCE THE COMPANY'S PHILOSOPHY IS JUST AS SIMPLE AS THE POETRY THAT INSPIRES ITS PRODUCTS. THE SEARCH FOR UTMOST QUALITY IS THE FIL ROUGE THAT RUNS THROUGH EVERY CHOICE AND PROJECT MADE BY VALDAMA. QUALITY CRAFTSMANSHIP TYPICAL OF THE AUTHENTIC MADE IN ITALY, FROM SELECTED RAW MATERIALS TO THE SKILLED HANDS THAT WORK THEM: THIS IS THE CHOICE THAT VALDAMA HAS MADE TO STAND OUT IN A MARKET OFTEN DEVALUED AND FLATTENED BY OFTEN OVERSTANDARDIZED PRODUCTS. AS EVERYONE KNOWS, SIMPLICITY IS NOT THAT EASY TO ACHIEVE.

Daniele Vitali,
Founder and CEO

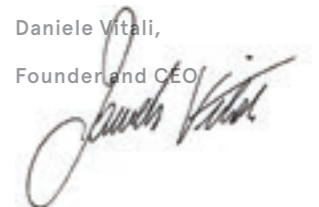

007

•
POD COLLECTION

POD 42 X 42 H15 • POD Ø45 H15 • POD 50 X 45 H15 • POD 60 X 38 H15

023

•
CUT COLLECTION

CUT 45 X 38 H12 • CUT 90 X 38 H12 (tutta vasca) • CUT 90 X 38 H12 (piano 27)
CUT 45 X 60 H16 • CUT 45 X45 H20 • CUT 45 X 25 H25

043

•
TRACK COLLECTION

TRACK 38 X 38 H12 • TRACK 60 X 38 H12 • TRACK 70 X 35 H10
TRACK Ø40 H14 (tondo) • TRACK 60 X 38 H14 (ovale)

061

•
SEED COLLECTION

SEED 45 X 40 H15 • SEED 55 X 42 H15 • SEED 55 X 40 H24 • SEED 70 X 40 H13 • SEED 90 X 42 H13
SEED 55 X 30 H18 • SEED Ø40 H18 • Ø45 H13 • SEED FREESTANDING • SEED WC • SEED BIDET

095

•
TRACE COLLECTION

TRACE Ø 40 H18 • TRACE 38 X 38 H15 • TRACE 65 X 38 H12

111

•
IL COLLECTION

IL FREESTANDING • IL WC • IL BIDET

127

•
SOUL COLLECTION

SOUL Ø 42 H 18 • SOUL Ø42 H10 • SOUL Ø42 H4 • SOUL Ø42 U • SOUL 55 X 38 H18
SOUL 55 X 38 H10 • SOUL 55 X 38 H4 • SOUL 55 X 38 U • SOUL 70 X 38 H 18 • SOUL 70 X 38 H10 • SOUL 70 X 38 H4 • SOUL 70 X 38 U
SOUL 55 X 42 H18 • SOUL 55 X 42 H10 • SOUL 55 X 42 H4 • SOUL 70 X 42 H18 • SOUL 70 X 42 H10 • SOUL 70 X 42 H4

155

•
START COLLECTION

START 45 X 45 H12 • START 72 X 45 H 12 • START 50 X 50 H12 • START 72 X 50 H 12
START FREESTANDING • START WC • START BIDET

DESIGN
· PROSPERO RASULO ·

POD

POD È UN LAVABO DA APPOGGIO,
DALLE FORME ORGANICHE
ISPIRATE ALLA NATURA

POD IS A COUNTERTOP WASHBASIN CHARACTERIZED
BY ORGANIC FORMS INSPIRED BY NATURE

POD COLLECTION

POD È UN GUSCIO CHE DIVENTA ALVEO
PER ACCOGLIERE L'ACQUA,
UN ELEMENTO AGILE, INDIPENDENTE E VERSATILE,
A CUI SI POSSONO AFFIDARE GRANDI ASPETTATIVE
DI COMFORT E BENESSERE.

UN PROGETTO SOFISTICATO CHE SVILUPPA
CURVE DIVERSE E DÀ ORIGINE A QUATTRO FORME
CHE SI SINTETIZZANO NELLE GEOMETRIE
PIÙ LEGATE ALLA NOSTRA MEMORIA:
IL CERCHIO, IL QUADRATO, IL RETTANGOLO, L'OVALE.
LA GAMMA DIMENSIONALE OFFRE AMPIA LIBERTÀ
DI SCELTA PER SODDISFARE TUTTE
LE ESIGENZE ESTETICHE E FUNZIONALI.

POD IS A SHELL DESIGNED TO RECEIVE WATER
- AN AGILE, INDEPENDENT AND VERSATILE ELEMENT -
WHILE REFLECTING THE COMFORT
AND WELLNESS OF THIS ELEMENT.

A SOPHISTICATED PROJECT,
DEVELOPING DIFFERENT CURVES WHICH GIVE ORIGIN
TO FOUR SHAPES THAT CAN BE REDUCED
TO SIMPLE GEOMETRY:
CIRCLE, SQUARE, RECTANGLE, OVAL.
THE WIDE RANGE OF SIZES MEETS ALL AESTHETICAL
AND FUNCTIONAL NEEDS.





42 x 42 x h15 cm

•
Appoggio
Sit-on



∅ 45 x h15 cm

•

Appoggio
Sit-on

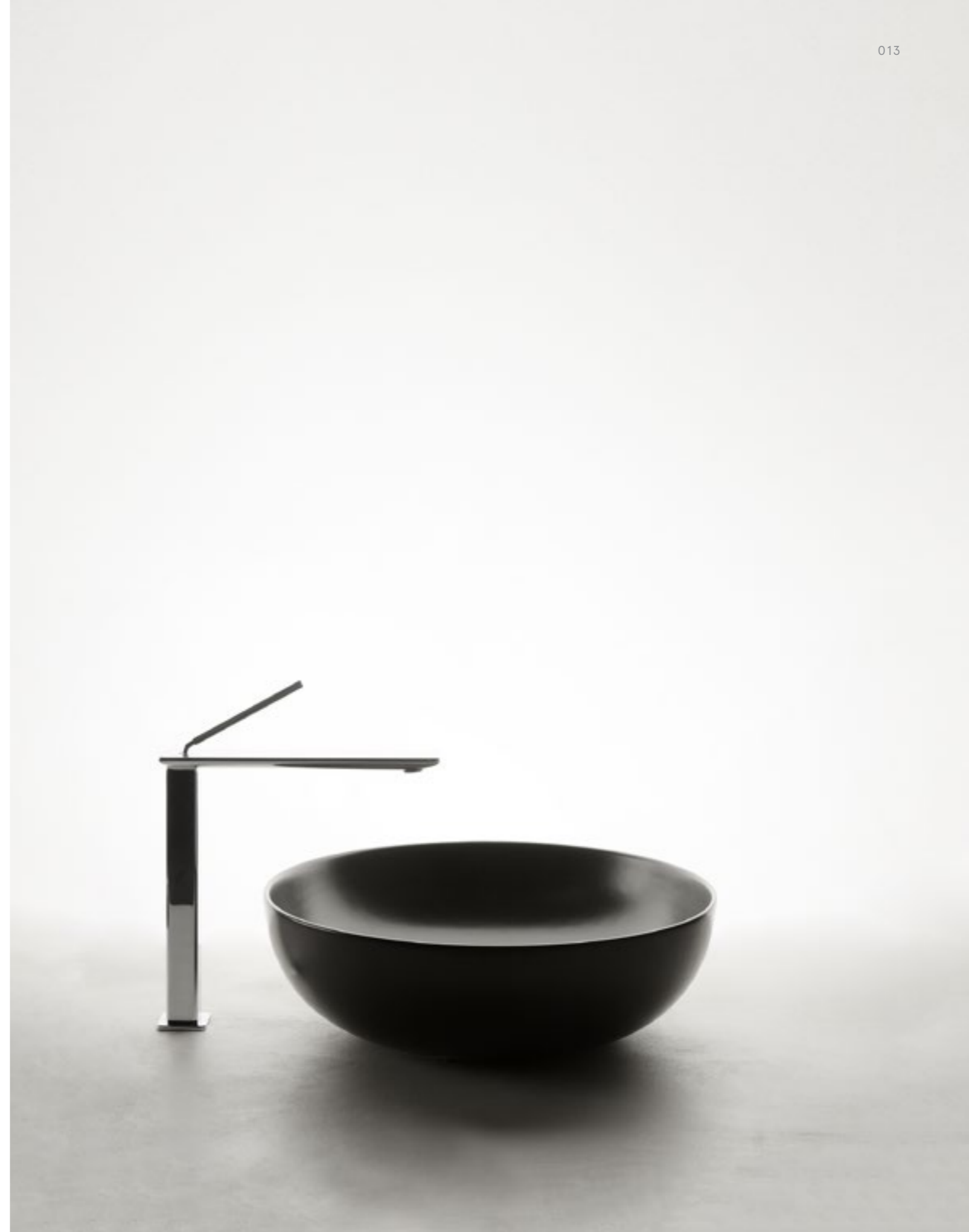



50 x 45 x h15 cm



Appoggio
Sit-on



60 x 38 x h15 cm

•

Appoggio
Sit-on



00



01



02



03

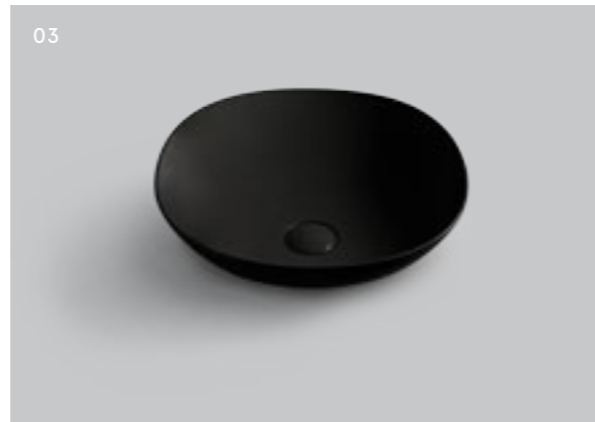

05

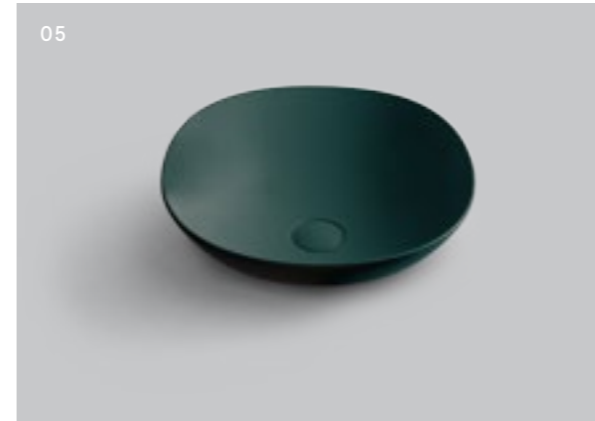

06



07

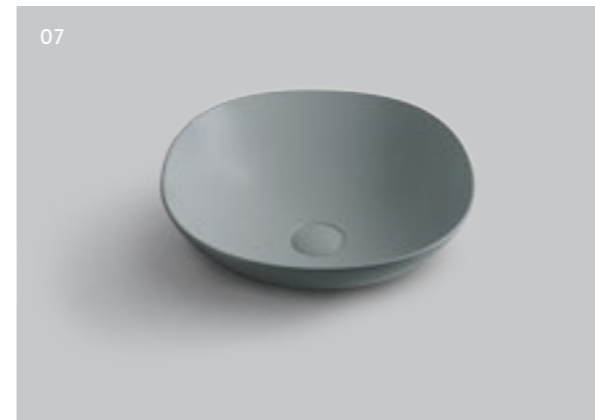

08



- | | |
|----|-------------------------------|
| 00 | BIANCO LUCIDO
GLOSSY WHITE |
| 01 | BIANCO OPACO
MATT WHITE |
| 02 | NERO LUCIDO
GLOSSY BLACK |
| 03 | NERO OPACO
MATT BLACK |
| 05 | LAGUNA |
| 06 | NUVOLA |
| 07 | TEMPESTA |
| 08 | BASENTO |

POD 42 X 42 H15

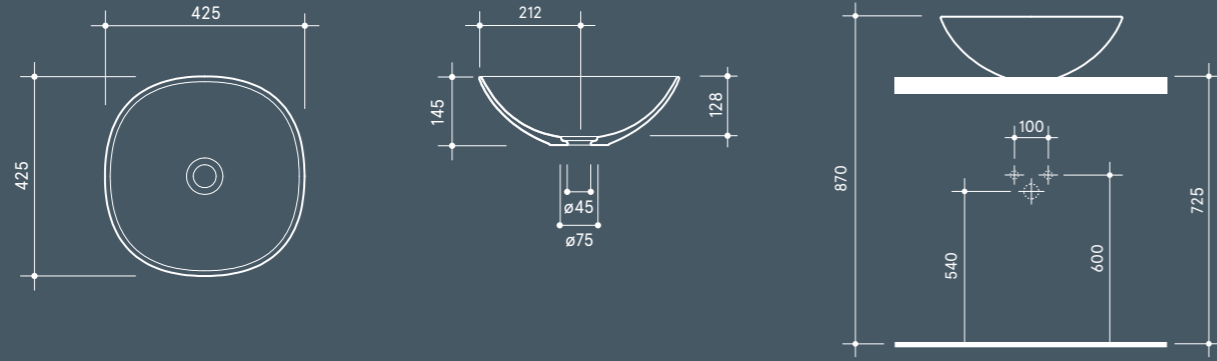

POD Ø 45 H15

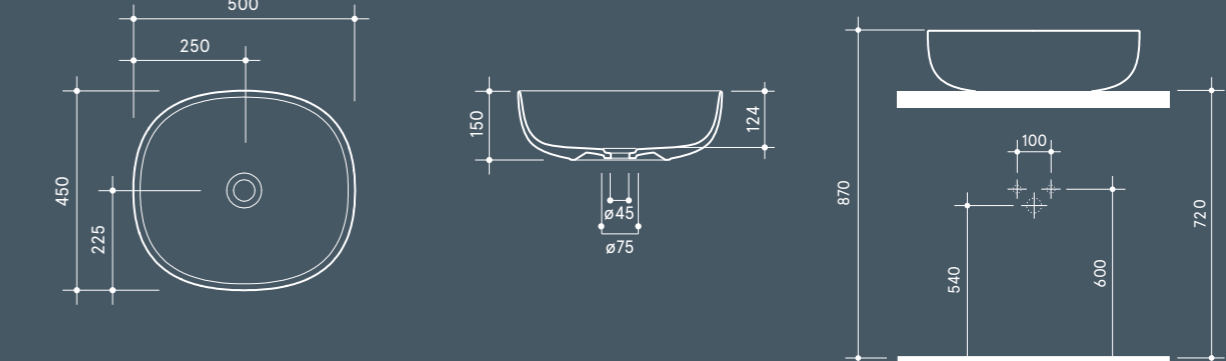
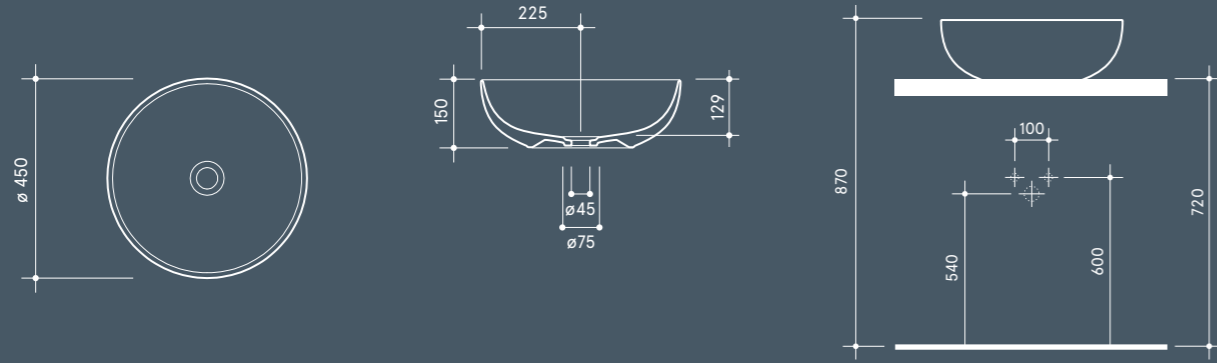

POD 50 X 45 H15

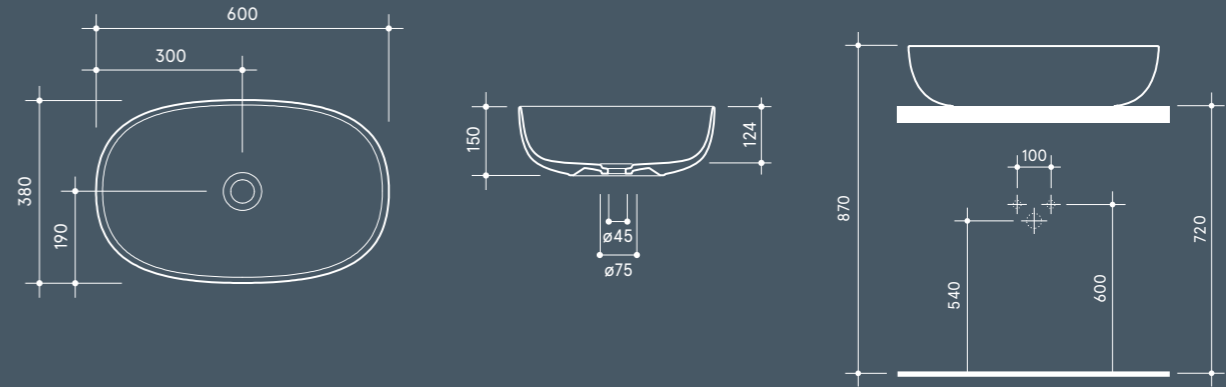

POD 60 X 38 H15

DESIGN
• PROSPERO RASULO •

CUT



CUT NASCE
DALLA RIDUZIONE,
DAL TAGLIO

CUT IS FOUNDED ON THE IDEA OF REDUCTION, OF CUTTING

CUT COLLECTION

COME RIVELA IL NOME,
CUT È UN LAVABO CHE NASCE DALL'IDEA
DELLA RIDUZIONE, DELL'ALLEGGERIMENTO
DEI VOLUMI E DEGLI SPESSORI, DEL TAGLIO.

COMPOSTO DA UN RITMICO ALTERNARSI DI VOLUMI,
CUT È UN LAVABO SCULTOREO COSTITUITO
DALLA GIUSTAPPOSIZIONE DI DUE FORME FINITE
E COMPLEMENTARI: L'INCAVO DEL BACINO
E IL PIANO D'APPOGGIO RIALZATO.

I DUE ELEMENTI, CONTENUTI IN UNA DOPPIA CORNICE IDEALE,
SI FONDONO PER DARE VITA A UN LAVABO
LA CUI VOCAZIONE È QUELLA DI DIVENTARE
PROTAGONISTA DELLA STANZA DA BAGNO.

CUT, AS THE NAME ITSELF REVEALS,
IS A WASHBASIN FOUNDED ON THE IDEA OF REDUCTION,
OF HONING LIGHTER VOLUMES AND THICKNESSES, OF CUTTING.

WITH A COMPOSITION BASED ON THE RHYTHMIC
ALTERNATION OF VOLUMES, CUT IS A SCULPTURAL WASHBASIN
CONSTITUTED BY THE JUXTAPOSITION OF TWO COMPLETE
AND COMPLEMENTARY FORMS:
THE HOLLOW OF THE BASIN AND THE RAISED COUNTERTOP.

THE TWO ELEMENTS, CONTAINED WITHIN AN IDEAL DOUBLE FRAME,
MERGE TO CREATE A WASHBASIN THAT ASPIRES TO BECOME
THE PROTAGONIST OF THE BATHROOM.



45 x 25 x h25 cm

•

Appoggio
Sit-on

Sospeso
Wall-hung



45 x 45 x h20 cm

•

Appoggio
Sit-on

Sospeso
Wall-hung





45 x 60 x h16 cm

•

Appoggio
Sit-on

Sospeso
Wall-hung



45 x 38 x h12 cm

•

Appoggio
Sit-on

Sospeso
Wall-hung





90 x 38 x h12 cm

•
Appoggio
Sit-on





90 x 38 x h12 cm

•

Appoggio
Sit-on





- | | |
|----|-------------------------------|
| 00 | BIANCO LUCIDO
GLOSSY WHITE |
| 01 | BIANCO OPACO
MATT WHITE |
| 02 | NERO LUCIDO
GLOSSY BLACK |
| 03 | NERO OPACO
MATT BLACK |
| 05 | LAGUNA |
| 06 | NUVOLA |
| 07 | TEMPESTA |
| 08 | BASENTO |

CUT 45 X 38 H12

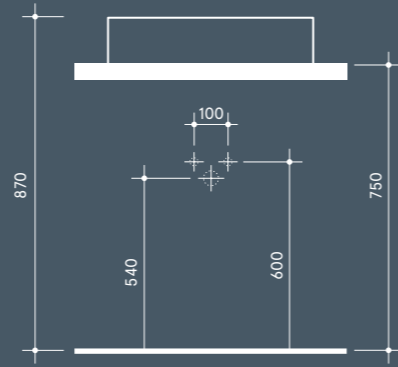
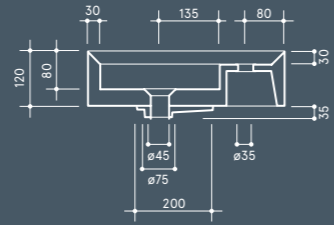
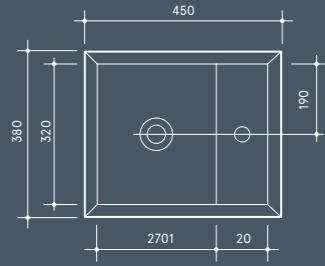

CUT 90 X 38 H12 (tutta vasca)

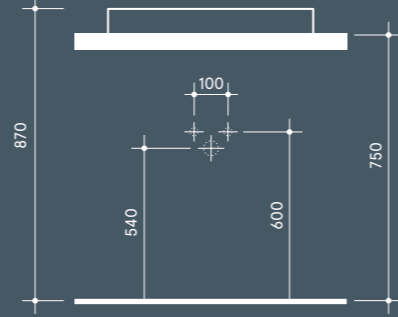
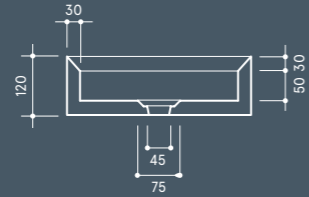
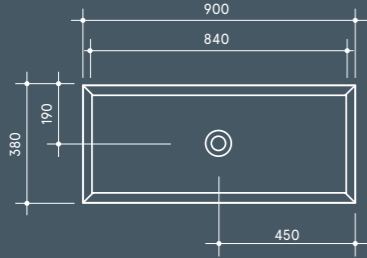

CUT 90 X 38 H12 (piano 27)

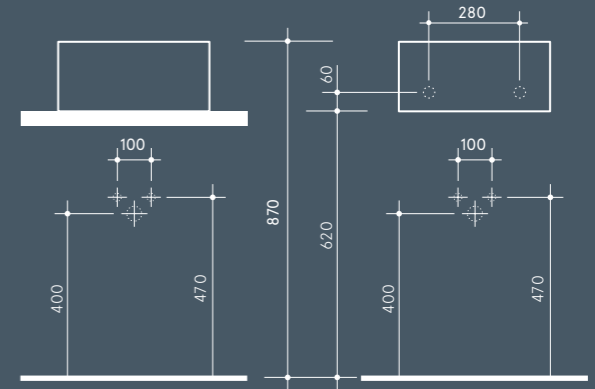
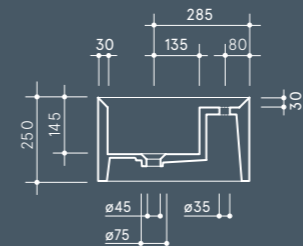
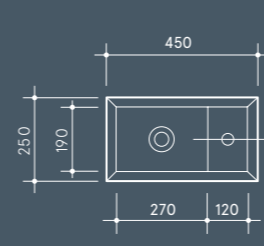
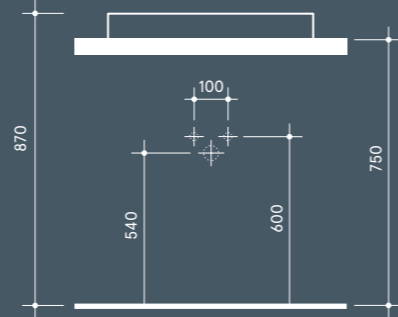
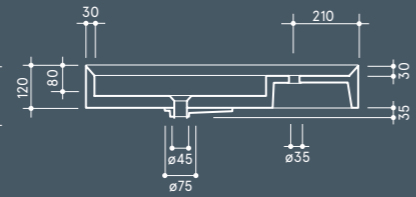
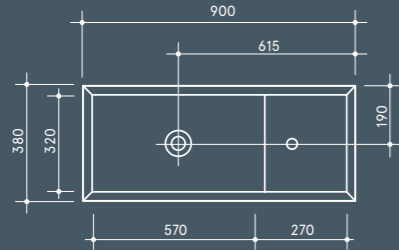

CUT 45 X 25 H25

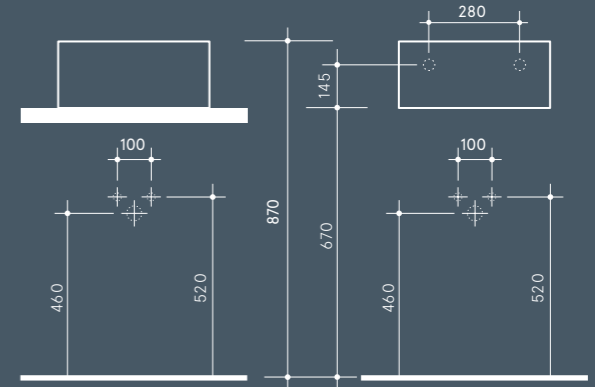
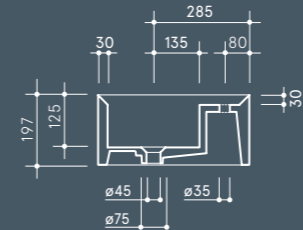
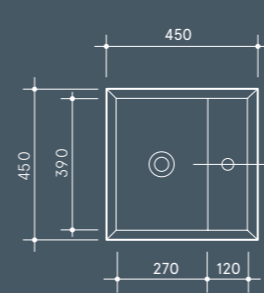

CUT 45 X 45 H20

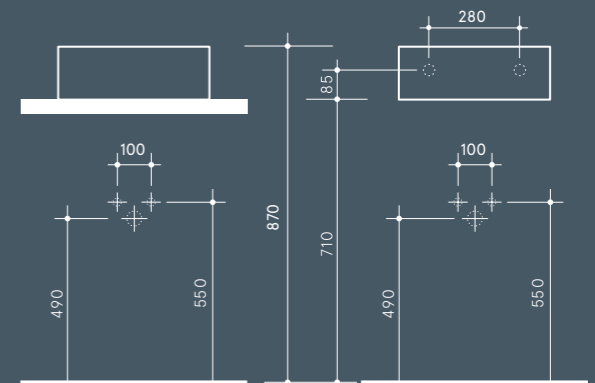
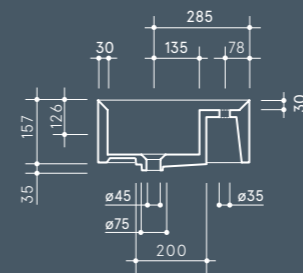
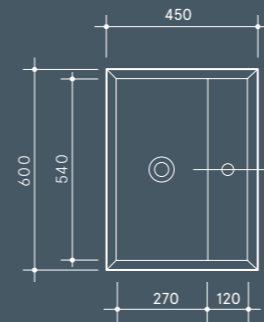

CUT 60 X 45 H16

DESIGN
· PROSPERO RASULO ·

TRACK

•

TRACK TRACCIA
DEI CONFINI DELINEANDO
UNA GEOMETRIA
SEMPLICE E ASSOLUTA

TRACK TRACES EDGES THAT DELINEATE A SIMPLE
AND ABSOLUTE GEOMETRY

TRACK COLLECTION

L'IDEA DEL CONTENERE E DARE FORMA A CIÒ CHE PER NATURA È MUTEVOLE E INCOSTANTE, COME L'ACQUA, RAPPRESENTA L'ISPIRAZIONE GENERATRICE DELLA FORMA DI TRACK.

TRACK, COME EVOCA IL NOME, TRACCIA DEI CONFINI DELINEANDO UNA GEOMETRIA SEMPLICE E ASSOLUTA, UNO SPAZIO QUASI ASTRATTO CHE ACCOGLIE AL SUO INTERNO LA MATERICITÀ MORBIDA DELLA CERAMICA. IN UN GIOCO DI FINI CONTRASTI MATERICI, TRACK INTERPRETA L'IDEA DELLA CORNICE, DI UNO SPAZIO MISURATO DA UN ORDINE RIGOROSO.

COSÌ CONCEPITO IL LAVABO ASSUME L'AUTONOMIA PROPRIA DI UN OGGETTO ARTISTICO.

.

THE IDEA OF CONTAINING AND GIVING FORM TO SOMETHING THAT IS CHANGEABLE AND FLUCTUATING BY NATURE, LIKE WATER, WAS THE INSPIRATION THAT GENERATED THE FORM OF TRACK.

TRACK, BY ITS VERY NAME, TRACES EDGES THAT DELINEATE A SIMPLE AND ABSOLUTE GEOMETRY, A SPACE OF ABSTRACTION THAT HARBOURS WITHIN IT THE SOFT MATERIAL QUALITY OF CERAMIC. IN A PLAY OF SOPHISTICATED MATERIAL CONTRASTS, TRACK INTERPRETS THE CONCEPT OF FRAME, IN A SPACE DELINEATED BY RIGOROUS ORDER.

THUS CONCEIVED, THE WASHBASIN ACHIEVES THE INDEPENDENCE OF AN OBJET D'ART.



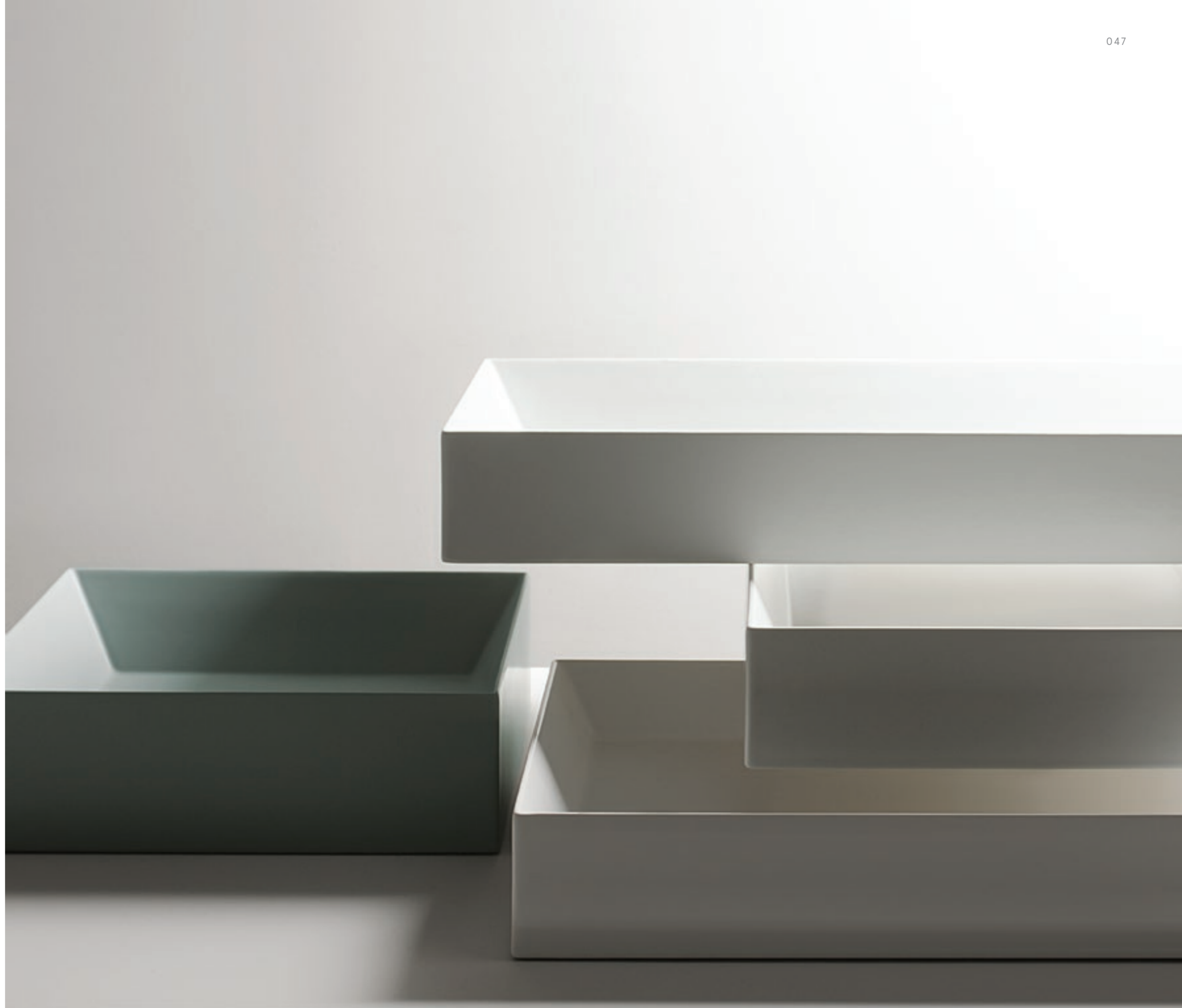



ø40 h14
tondo



Appoggio
Sit-on



60 x 38 h14
ovale



Appoggio
Sit-on



38 x 38 x h12 cm

•

Appoggio
Sit-on



60 x 38 x h12 cm

•

Appoggio
Sit-on





70 x 35 x h10 cm



Appoggio
Sit-on

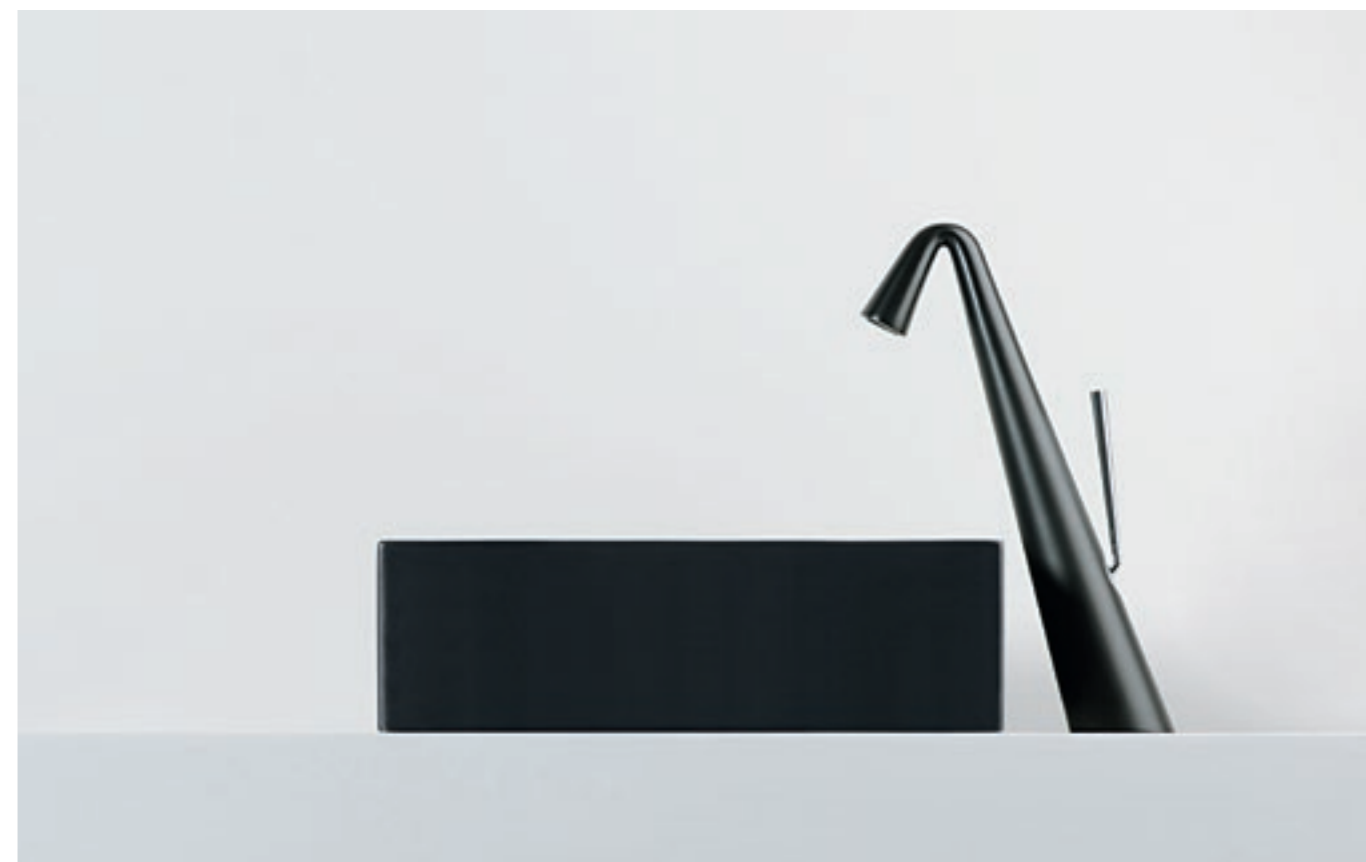

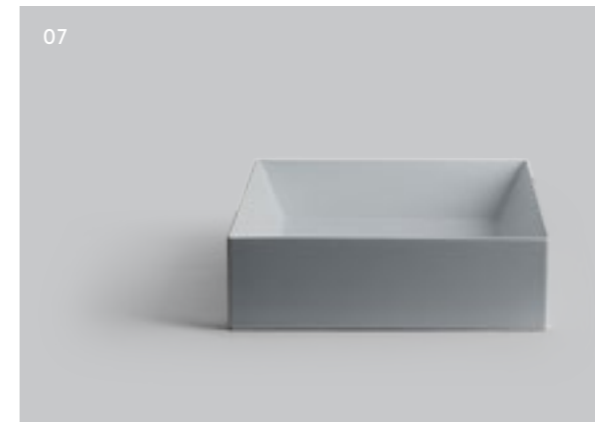

- | | |
|----|-------------------------------|
| 00 | BIANCO LUCIDO
GLOSSY WHITE |
| 01 | BIANCO OPACO
MATT WHITE |
| 02 | NERO LUCIDO
GLOSSY BLACK |
| 03 | NERO OPACO
MATT BLACK |
| 05 | LAGUNA |
| 06 | NUVOLA |
| 07 | TEMPESTA |
| 08 | BASENTO |

TRACK 38 X 38 H12

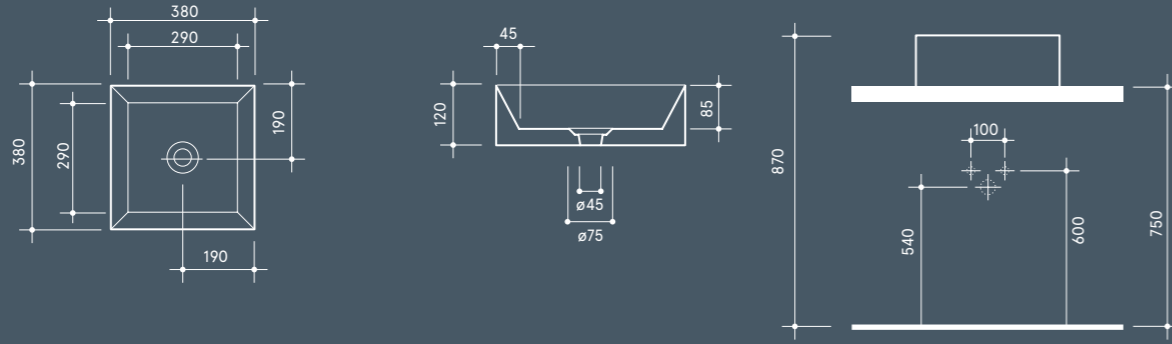

TRACK 60 X 38 H12

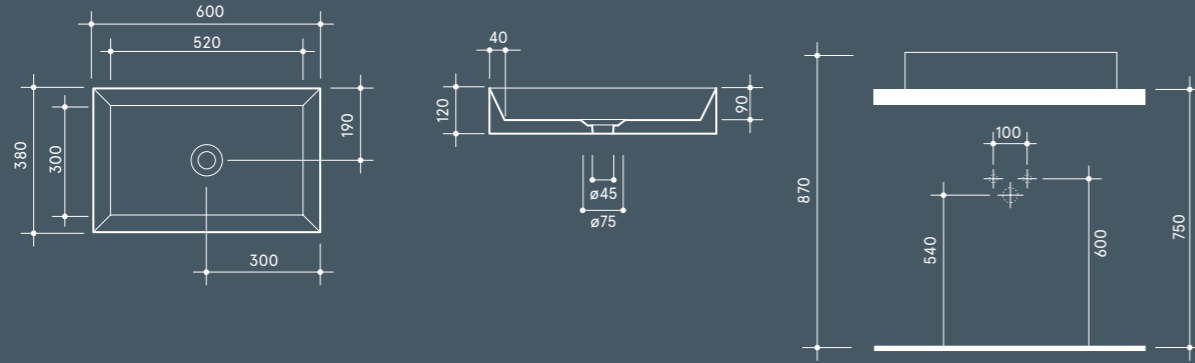

TRACK 70 X 35 H10

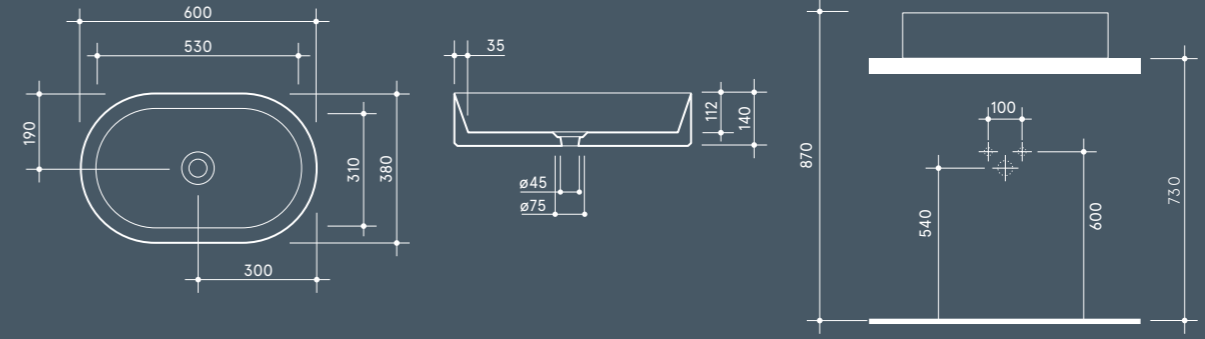
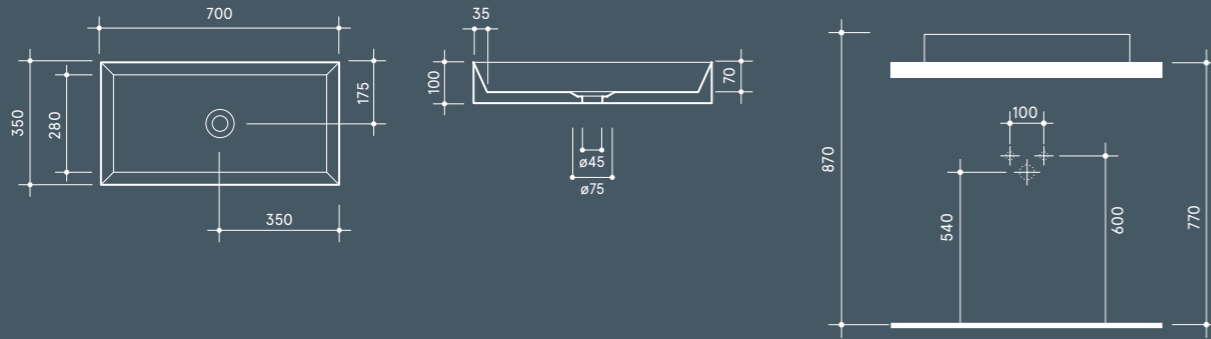

TRACK 60 X 38 H14 (ovale)

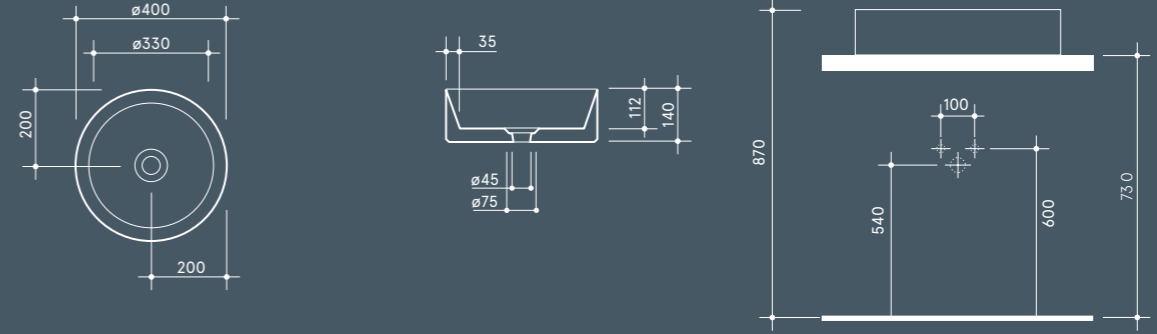
TRACK $\varnothing 40$ H14 (tondo)

DESIGN
· PROSPERO RASULO ·

SEED

•

SEED
È UN SEGNO GENERATORE
DI ARMONIA

SEED IS A SIGN OF ARMONY

SEED COLLECTION

LA COLLEZIONE SEED,
DISEGNATA DA PROSPERO RASULO,
NASCE DALL'IDEA DI UN SEME
CHE NUTRITO GENERA ARMONIA.

SEED COME CULLA DI VITA,
DI BELLEZZA, DI ORNAMENTO.

SEME CHE SI NUTRE DI ACQUA PER
DARE ORIGINE A UNA NUOVA SPECIE.
UN INVOLUCRO CHE AL TEMPO STESSO
RACCHIUDE UNA VITA E GARANTISCE
LA SUA CRESCITA.

•

SEED COLLECTION,
DESIGNED BY PROSPERO RASULO,
WAS BORN FROM THE IDEA OF A SEED
THAT GENERATES A FORM IF FED.

SEED IS LIKE A CRADLE OF LIFE,
BEAUTY AND ORNAMENT.

SEED FEEDS OF WATER TO GIVE LIFE
TO A NEW SPECIES.
A CASING WHICH CONTAINS LIFE
AND GUARANTEES GROWTH
AT THE SAME TIME.



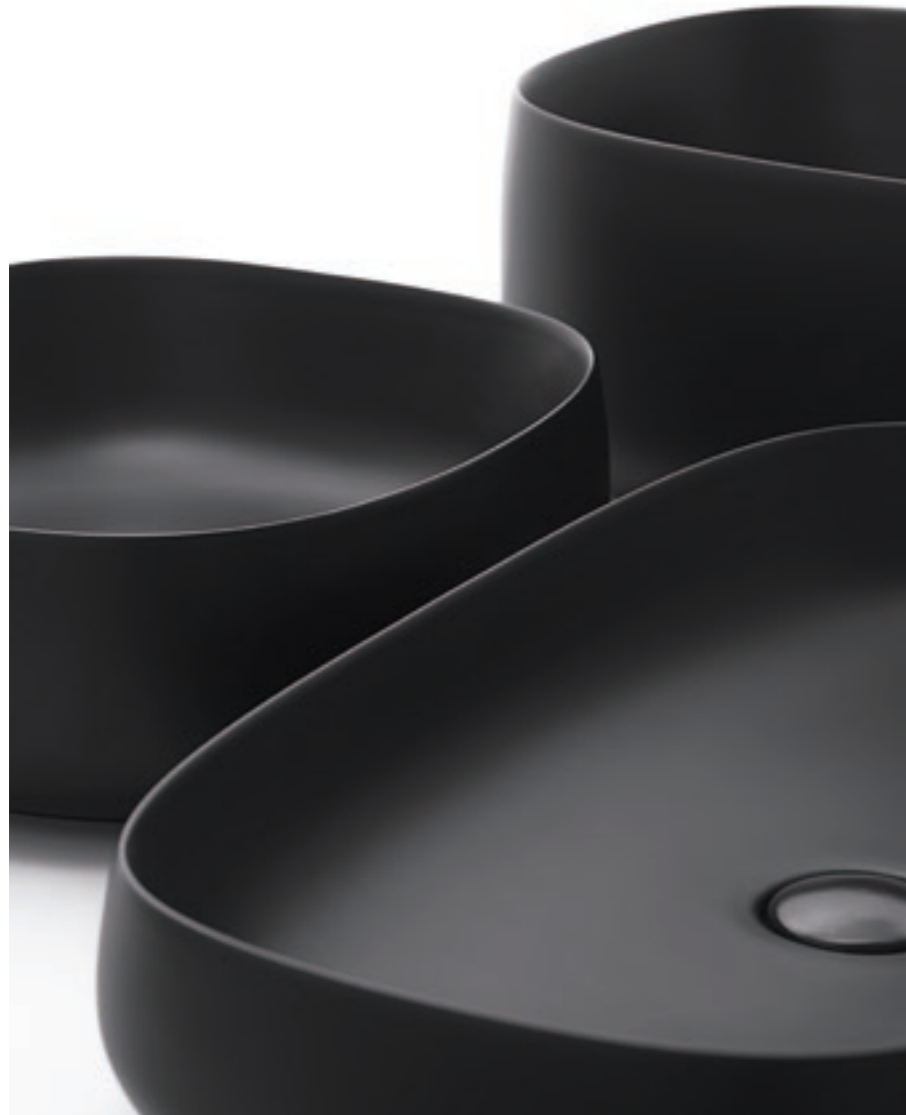

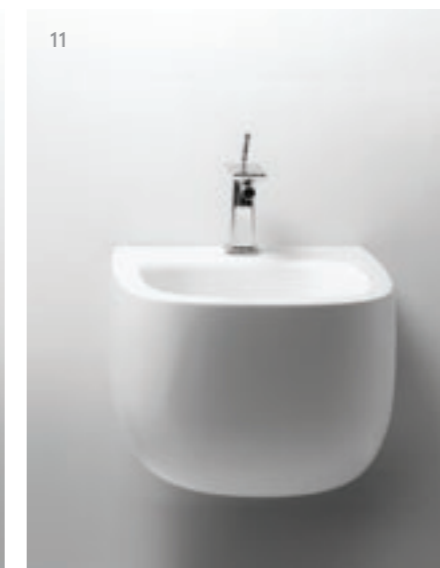

- | | |
|----|---------------|
| 01 | 45 x 40 x h15 |
| 02 | 55 x 42 x h15 |
| 03 | 55 x 30 x h18 |
| 04 | 55 x 40 x h24 |
| 05 | 90 x 42 x h13 |
| 06 | 70 x 40 x h13 |
| 07 | ∅ 45 h 13 |
| 08 | ∅ 40 h18 |
| 09 | Freestanding |
| 10 | Wc sospeso |
| 11 | Bidet sospeso |

55 x 30 x h18

•

Appoggio
Sit-on





45 x 40 x h15 cm



Appoggio
Sit-on



55 x 42 x h15 cm

•

Appoggio
Sit-on



55 x 40 x h24 cm

•

Appoggio
Sit-on



55 x 30 x h18 cm

•

Appoggio
Sit-on



70 x 40 x h13 cm

•

Appoggio
Sit-on



90 x 42 x h13 cm

•

Appoggio
Sit-on





ø 40 h18 cm



Appoggio
Sit-on





Ø 45 h13 cm



Appoggio
Sit-on



Freestanding
42,5 x 42,5 x h90 cm

•

Scarico a terra
Floor mounted

Scarico a parete/terra
Face wall





Wc & Bidet
38 x 55 x h28 cm

•

Sospesi
Wall-hung





Wc & Bidet
38 x 55 x h28 cm



Sospesi
Wall-hung





- | | |
|----|-------------------------------|
| 00 | BIANCO LUCIDO
GLOSSY WHITE |
| 01 | BIANCO OPACO
MATT WHITE |
| 02 | NERO LUCIDO
GLOSSY BLACK |
| 03 | NERO OPACO
MATT BLACK |
| 04 | ZOLFO |
| 05 | LAGUNA |
| 06 | NUVOLA |
| 07 | TEMPESTA |
| 08 | BASENTO |

SEED 45 X 40 H15

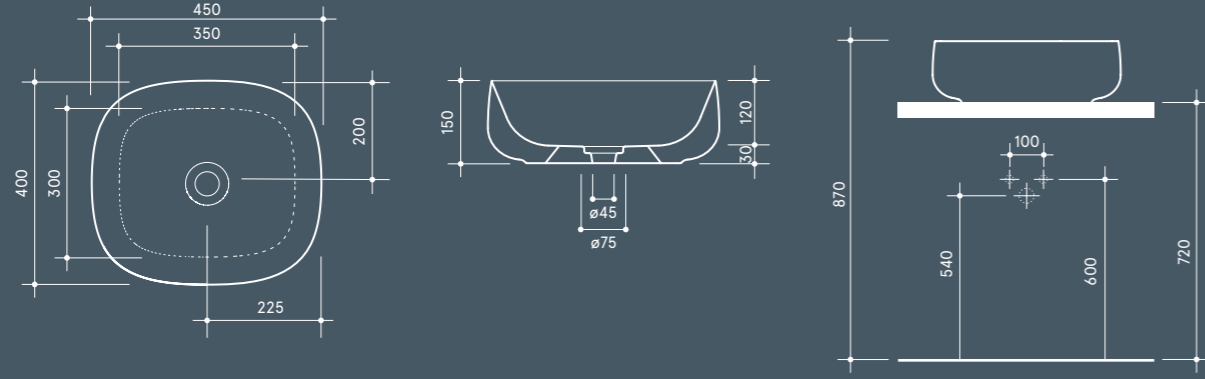

SEED 55 X 42 H15

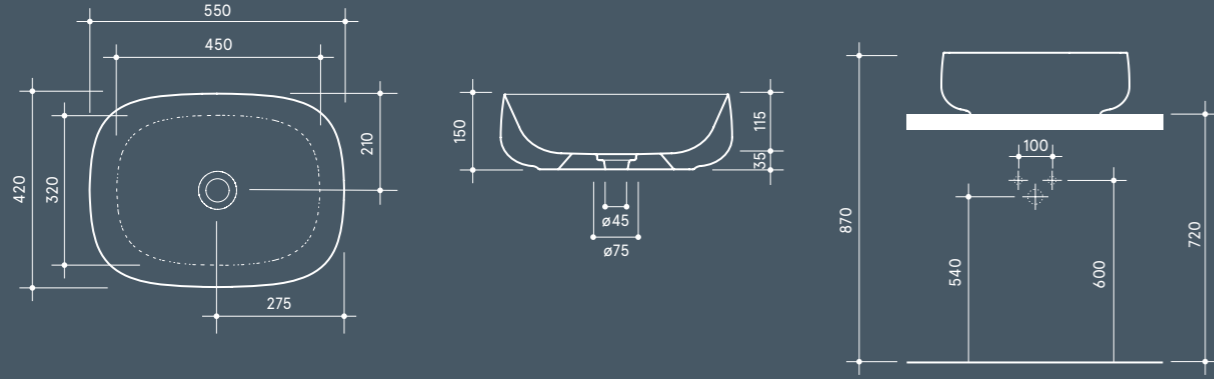

SEED 55 X 30 H18

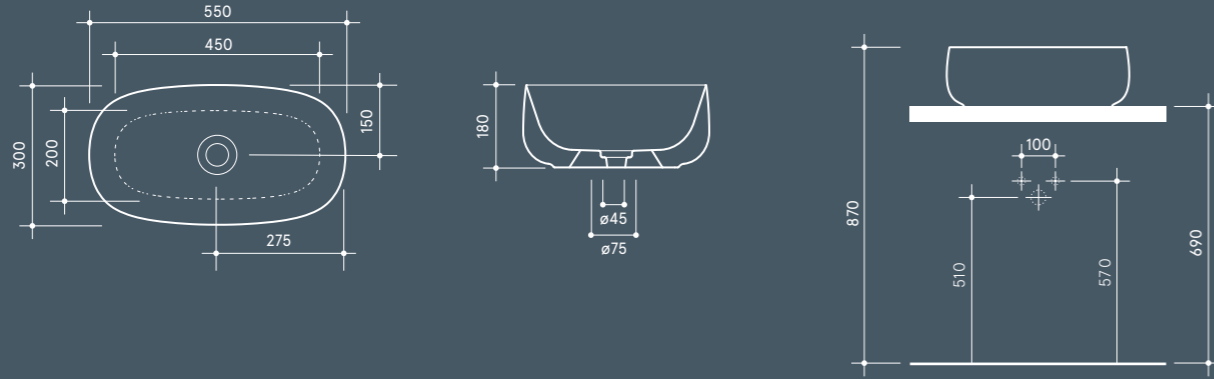

SEED 55 X 40 H24

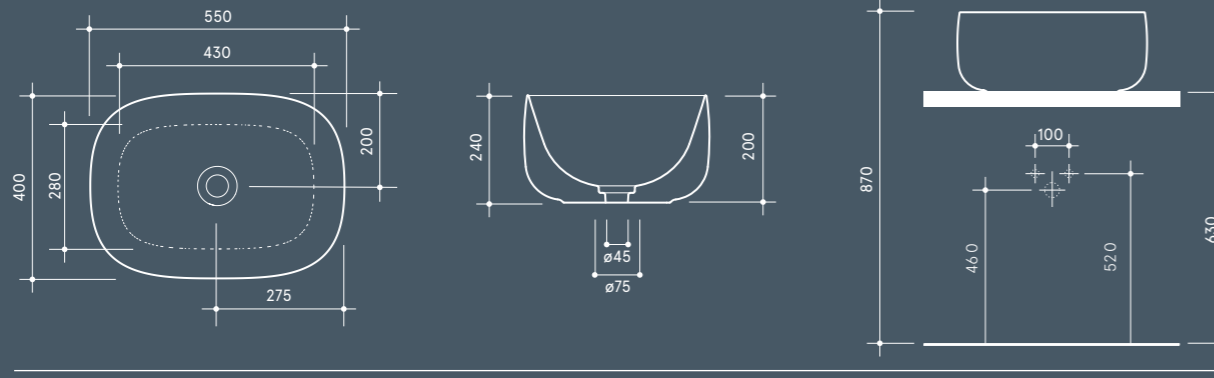

SEED 70 X 40 H13

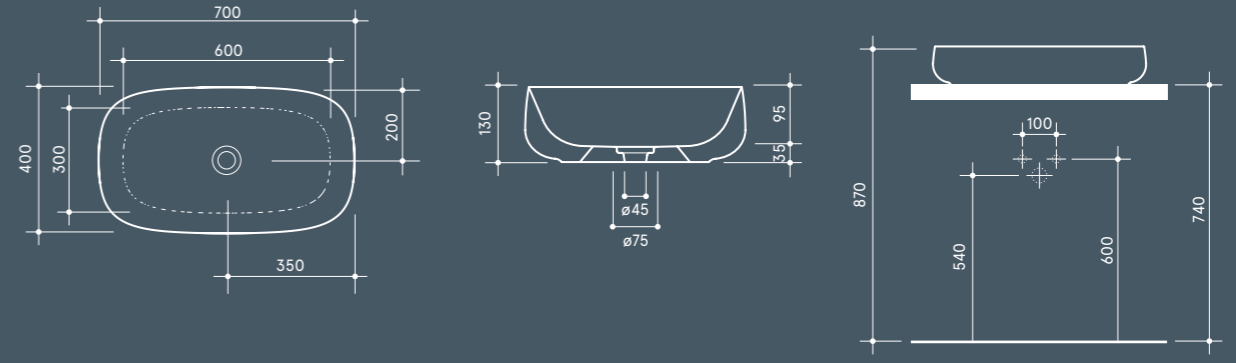

SEED 90 X 42 H13

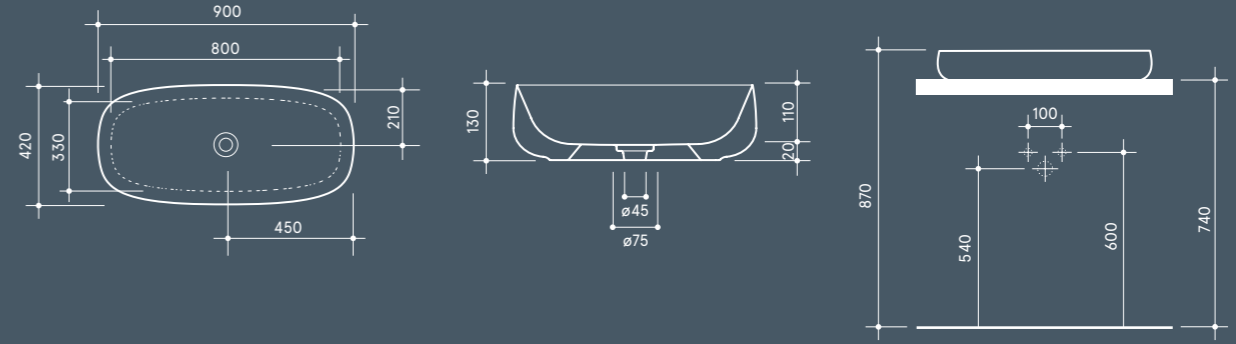

SEED Ø45 H13

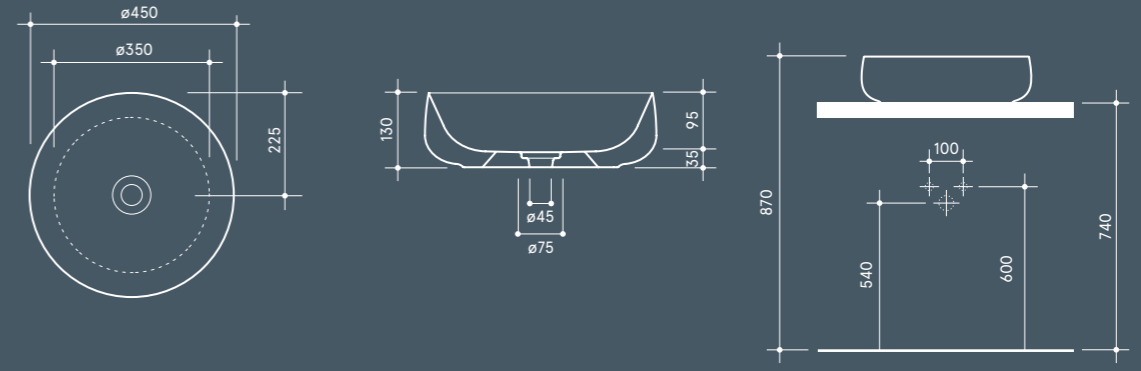

SEED Ø40 H18

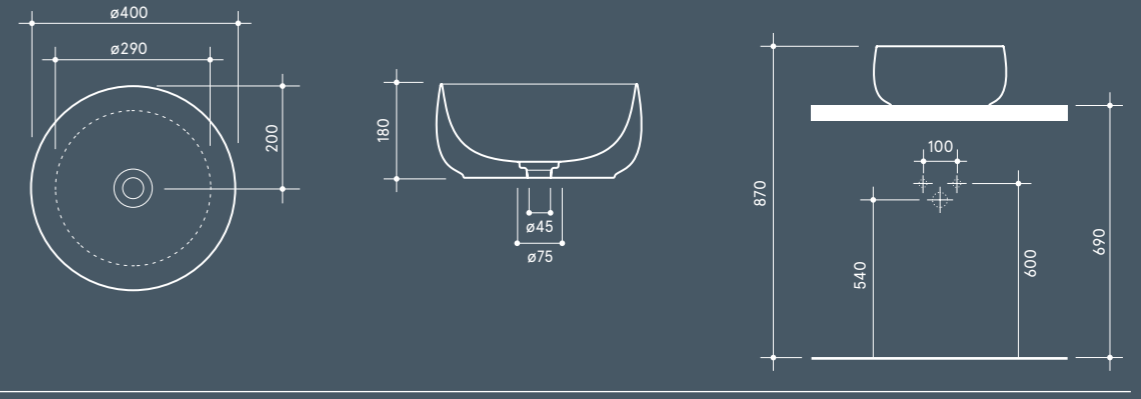

SEED FREESTANDING



SCARICO A TERRA
FLOOR DRAINAGE

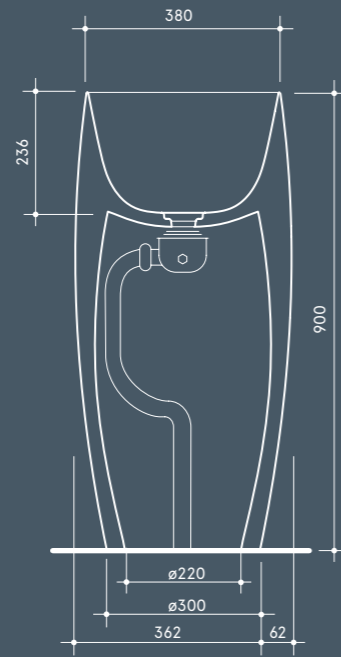

SCARICO A PARETE/TERRA
WALL/FLOOR DRAINAGE

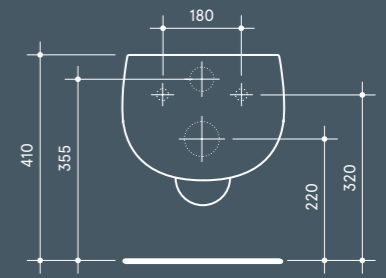
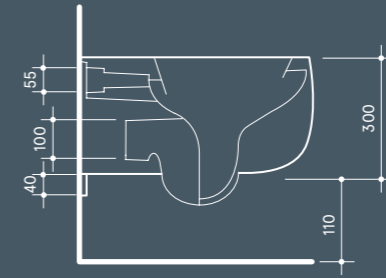
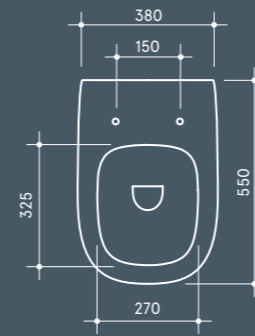
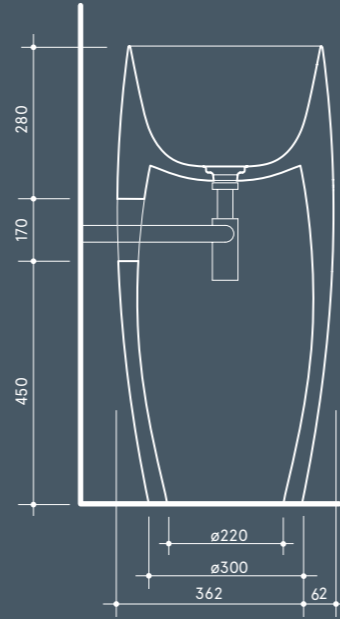

SEED WC

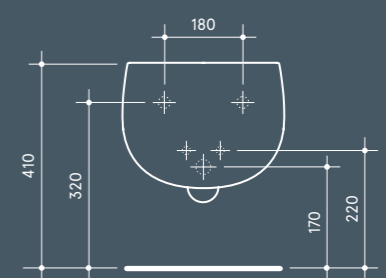
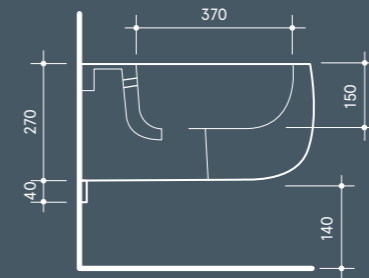
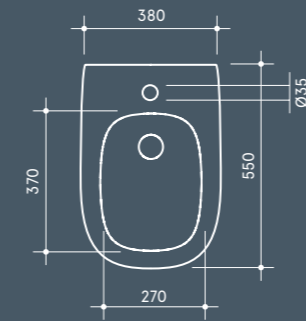

SEED BIDET

DESIGN

· GIANNI VENEZIANO · LUCIANA DI VIRGILIO V+T ·

TRACE

.

UNA TRACCIA CHE
TESTIMONIA UN PASSAGGIO
DI QUALCOSA
CHE C'ERA E CI SARÀ

A TRACE WHICH WITNESSES THE CHANGE
FROM SOMETHING THAT WAS TO SOMETHING THAT WILL BE

TRACE COLLECTION

TRACE È UN LAVABO DA APPOGGIO CHE SI DISTINGUE PER L'IMPATTO PLASTICO ED EVOCA IL LAVORIO SCULTOREO DELL'ACQUA SULLA MATERIA.

DISPONIBILE IN TRE FORME DIFFERENTI, RETTANGOLARE, QUADRATA E TONDA E IN TRE DIMENSIONI, SI PUÒ SCEGLIERE NELLA FINITURA OPACA O LUCIDA, E NELLE VARIANTI BIANCO, NERO O COLORATO.

.

TRACE IS A COUNTERTOP WASHBASIN CHARACTERIZED BY ITS PLASTIC EFFECT WHICH RECALLS THE SCULPTING EFFECTS OF WATER ON DIFFERENT MATERIALS.

AVAILABLE IN THREE DIFFERENT SHAPES - RECTANGULAR, SQUARE AND ROUND - AND IN THREE DIFFERENT SIZES; AVAILABLE IN MATTE OR GLOSSY FINISH AND VARIANTS WHITE, BLACK OR COLORED.



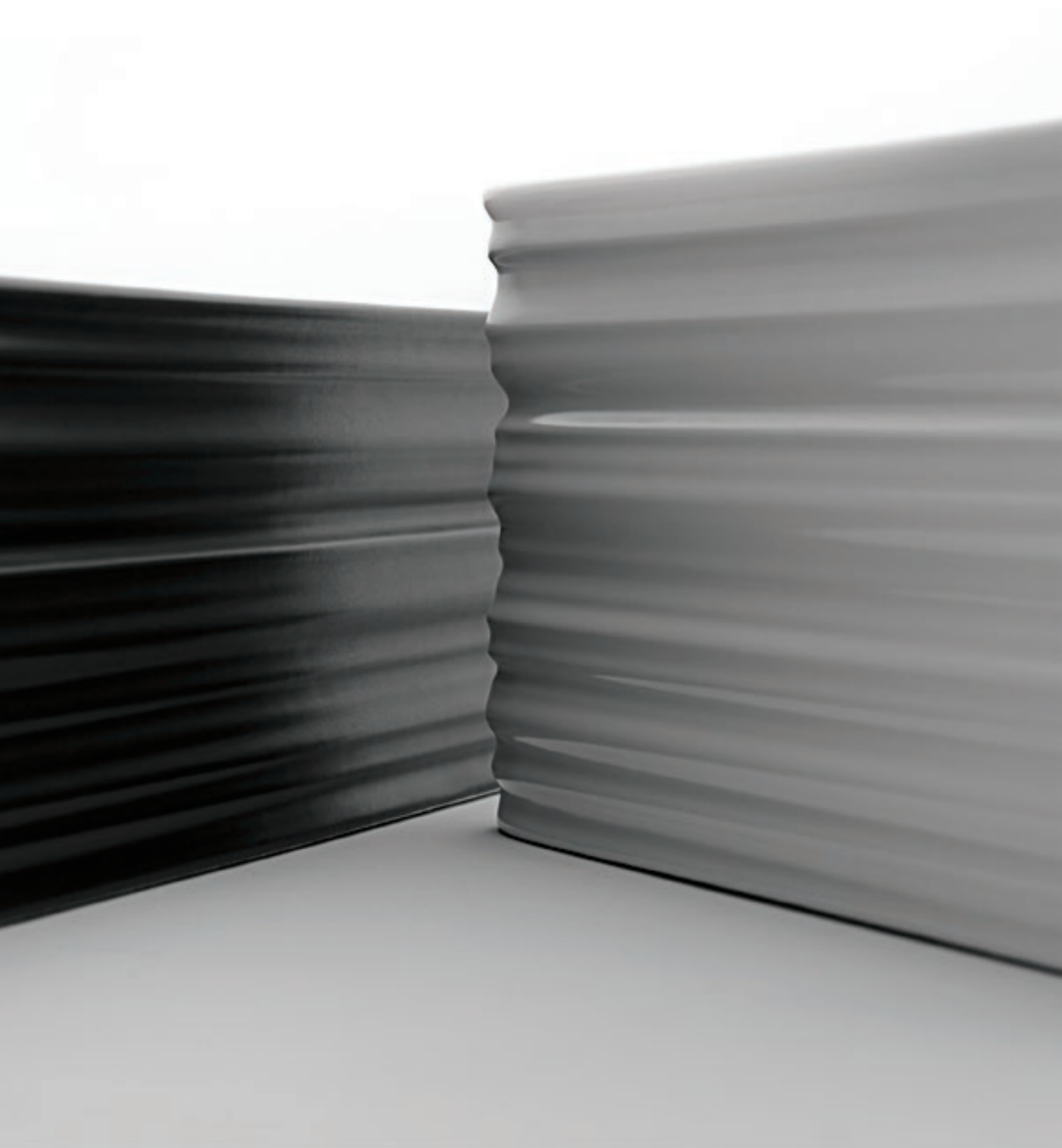

ø40 h18 cm



Appoggio
Sit-on



ø40 h18 cm

•

Appoggio
Sit-on





38 x 38 x h15 cm

•

Appoggio
Sit-on



65 x 38 x h12 cm

•

Appoggio
Sit-on





- | | |
|----|-------------------------------|
| 00 | BIANCO LUCIDO
GLOSSY WHITE |
| 01 | BIANCO OPACO
MATT WHITE |
| 02 | NERO LUCIDO
GLOSSY BLACK |
| 03 | NERO OPACO
MATT BLACK |
| 06 | NUVOLA |
| 07 | TEMPESTA |
| 08 | BASENTO |

TRACE 38 X 38 H15

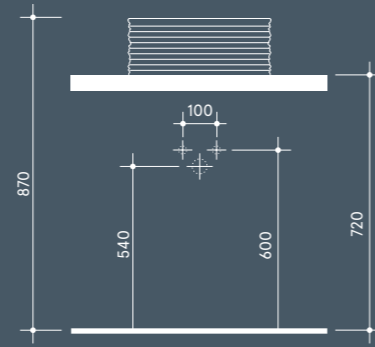
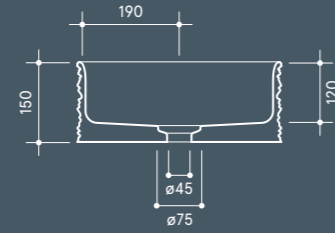
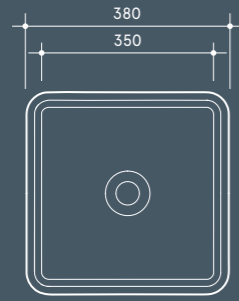

TRACE 65 X 38 H12

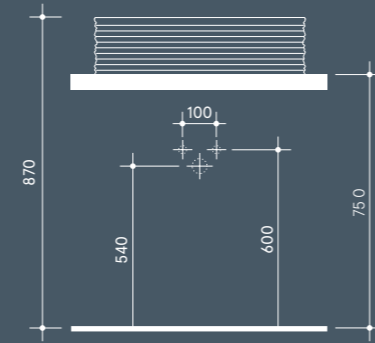
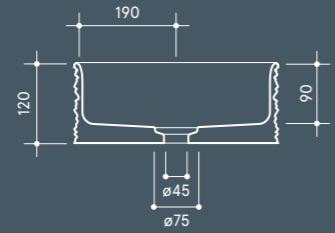
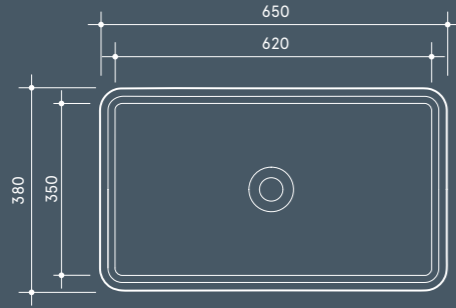

TRACE Ø40 H180

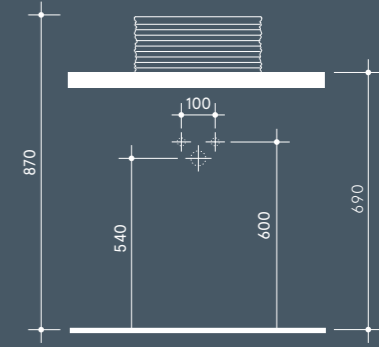
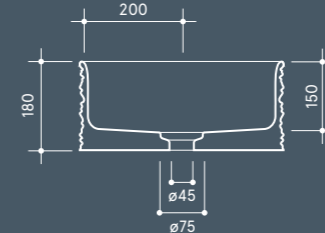
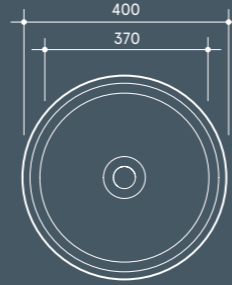

DESIGN
· PROSPERO RASULO ·

IL

•

IL LA POETICA
DELLA BELLEZZA ESSENZIALE,
DELLA CONCRETEZZA

IL POETICS OF ESSENTIAL BEAUTY, POETICS OF CONCRETENESS



IL COLLECTION

UNA SOLUZIONE D'ARREDO CHE INTERPRETA
CON SUCCESSO LE FORME ESSENZIALI
PERFETTAMENTE ADATTABILI IN OGNI AMBIENTE BAGNO.
LA COLLEZIONE IL NATA PER RISPONDERE
ALLE VARIE ESIGENZE DI PROGETTISTI E CLIENTI,
VA AD AMPLIARE LA GAMMA DEI PRODOTTI VALDAMA
CARATTERIZZATI DA UN'ESTETICA CONTEMPORANEA.

LA COLLEZIONE COMPRENDE LAVABO,
FREESTANDING
E I SANITARI NELLA VERSIONE SOSPESA.
DISPONIBILI NELLA FINITURA OPACA E LUCIDA
E NELLE COLORAZIONI
BIANCO, NERO, NUVOLA E TEMPESTA.

•
THIS COLLECTION, DISTINGUISHED
THANKS TO ITS ESSENTIAL FORMS,
IS PERFECTLY ADJUSTABLE
WITH ANY KIND OF BATH AMBIENT.
THE NEW LINE, BORN FOR DESIGNER'S
AND ARCHITECT'S NEEDS,
INCREASES THE VALDAMA PRODUCT RANGE
CHARACTERIZED FOR A CONTEMPORARY AESTHETIC.

IL COLLECTION, INCLUDES THE WASHBASIN
FREESTANDING
AND THE WALL HUNG SANITARY WARES.
AVAILABLE IN MATT AND GLOSSY FINISHING
IN WHITE, BLACK, NUVOLA AND TEMPESTA COLOR.





•
IL Freestanding

IL WC Sospeso

IL Bidet Sospeso



Freestanding
Ø 42 h90 cm

•

Scarico a terra
Floor mounted

Scarico a parete/terra
Face wall



Freestanding
Ø 42 h90 cm

•

Scarico a terra
Floor mounted

Scarico a parete/terra
Face wall



WC & Bidet
35 x 54 x h28 cm

•

Sospesi
Wall-hung



WC & Bidet
35 x 54 x h28 cm

•

Sospesi
Wall-hung





- | | |
|----|-------------------------------|
| 00 | BIANCO LUCIDO
GLOSSY WHITE |
| 01 | BIANCO OPACO
MATT WHITE |
| 02 | NERO LUCIDO
GLOSSY BLACK |
| 03 | NERO OPACO
MATT BLACK |
| 06 | NUVOLA |
| 07 | TEMPESTA |

IL FREESTANDING

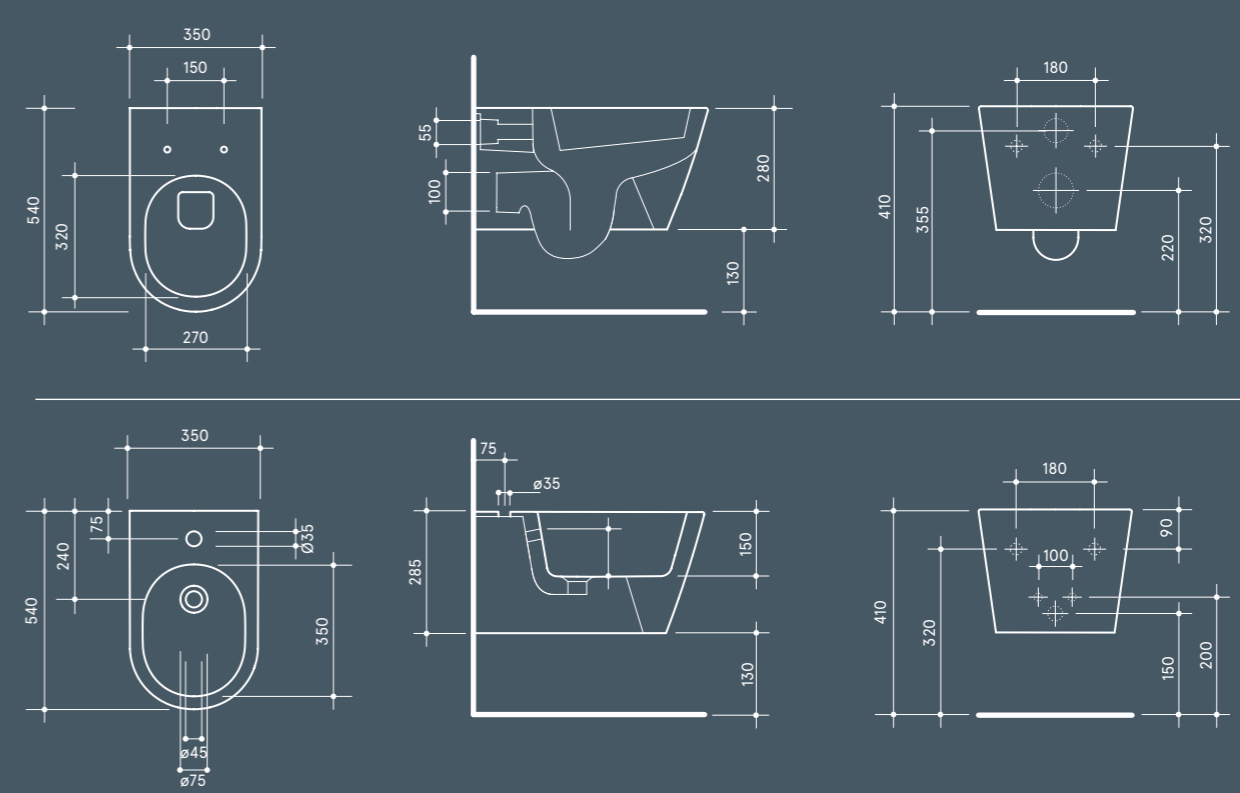
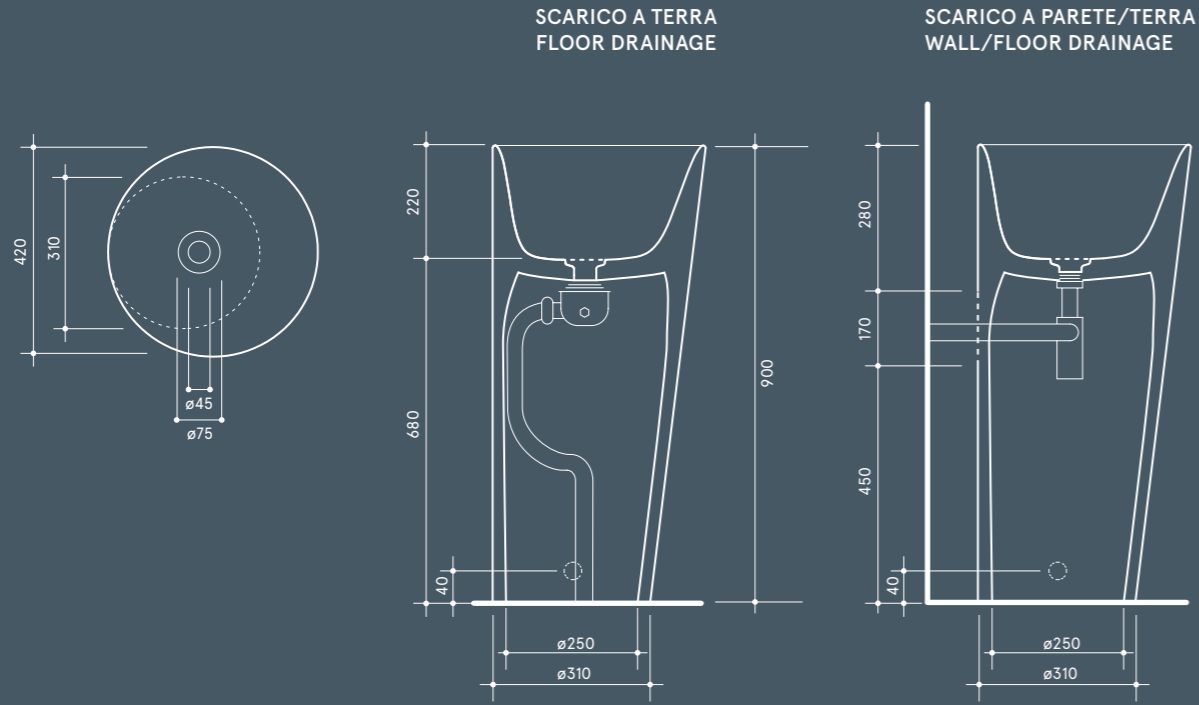

IL WC

IL BIDET

DESIGN
· MONIA MARZANO ·

SOUL

•

LA SEMPLICITÀ,
QUALUNQUE ESSA SIA,
È UNA CONQUISTA

WHATEVER FORM IT MAY TAKE, SIMPLICITY IS AN ACHIEVEMENT

SOUL COLLECTION

SOUL È UNA COLLEZIONE DOTATA DI SPICCATÀ IDENTITÀ, SOFISTICATA E INNOVATIVA AL TEMPO STESSO, IMMEDIATAMENTE RICONOSCIBILE PER I VOLUMI CONTENUTI E PER LA CAPACITÀ DI GOVERNARE LO SCORRERE DELL'ACQUA IN MODO NATURALMENTE E SENSUALE. I LAVABI DELLA COLLEZIONE SOUL OFFRONO GRANDI OPPORTUNITÀ DI PERSONALIZZAZIONE POICHÈ SONO REALIZZATI IN TRE DIVERSE ALTEZZE; SONO INOLTRE DISPONIBILI SIA NELLA VERSIONE DA SEMINCASSO CHE DA APPOGGIO.

SOUL IS A COLLECTION WITH A REMARKABLE IDENTITY, SOPHISTICATED AND INNOVATIVE AT THE SAME TIME, IMMEDIATELY RECOGNIZABLE FOR REDUCED VOLUMES AND FOR ITS CAPACITY TO HANDLE THE WATER FLOWING IN A NATURAL AND SENSUAL WAY. WASHBASINS FROM SOUL COLLECTION OFFER DIFFERENT CUSTOMIZATION POSSIBILITIES AS THEY ARE REALIZED IN THREE DIFFERENT HEIGHTS; MOREOVER THEY ARE AVAILABLE IN SEMI-RECESSED AND SIT-ON VERSION.



ø42 h10 cm

•

Incasso
Recessed





•
ø42 h10 cm

•
Incasso
Recessed

•
ø42 h4 cm

•
Incasso
Recessed

•
ø42 h18 cm

•
Appoggio
Sit-on





55 x 38 x h18 cm



Appoggio
Sit-on

55 x 38 x h4 cm



Incasso
Recessed

55 x 38 x h10 cm



Incasso
Recessed





70 x 38 x h18 cm



Appoggio
Sit-on

70 x 38 x h4 cm



Incasso
Recessed

70 x 38 x h10 cm



Incasso
Recessed



WC & Bidet
35 x 54 x h28 cm

•

Sospesi
Wall-hung

70 x 38 x h18 cm

•

Appoggio
Sit-on



55 x 42 x h18 cm

•

Sospeso
Wall-hung

Appoggio
Sit-on

55 x 42 x h4 cm

•

Incasso
Recessed

55 x 42 x h10 cm

•

Incasso
Recessed





70 x 42 x h18 cm

Sospeso
Wall-hung

Appoggio
Sit-on

70 x 42 x h4 cm

Incasso
Recessed

70 x 42 x h10 cm

Incasso
Recessed





01 70 x 38 x h4 cm

02 55 x 38 x h4 cm

03 ø42 h4 cm

•
Sottopiano
Under-top

•
Sottopiano
Under-top

•
Sottopiano
Under-top



- | | |
|----|-------------------------------|
| 00 | BIANCO LUCIDO
GLOSSY WHITE |
| 01 | BIANCO OPACO
MATT WHITE |
| 02 | NERO LUCIDO
GLOSSY BLACK |
| 03 | NERO OPACO
MATT BLACK |
| 06 | NUVOLA |
| 07 | TEMPESTA |
| 08 | BASENTO |

SOUL Ø42 H4 • U

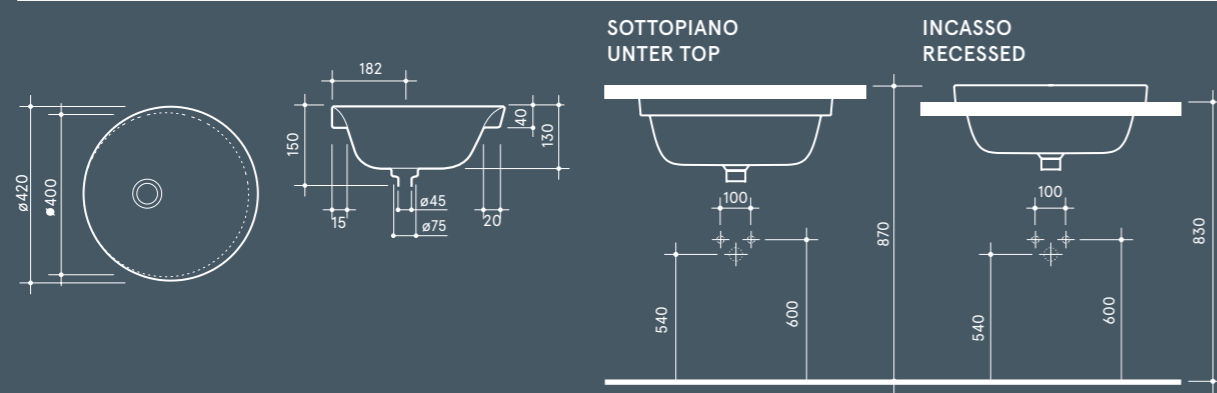

SOUL Ø42 H10

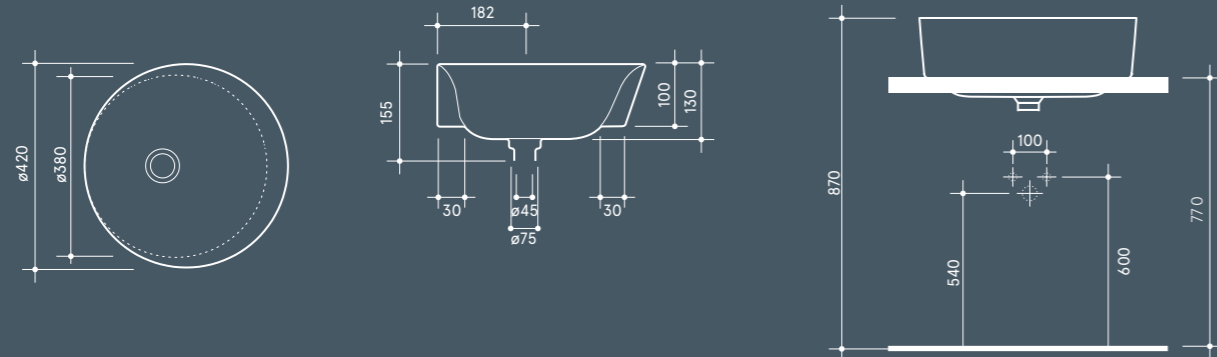

SOUL Ø42 H18

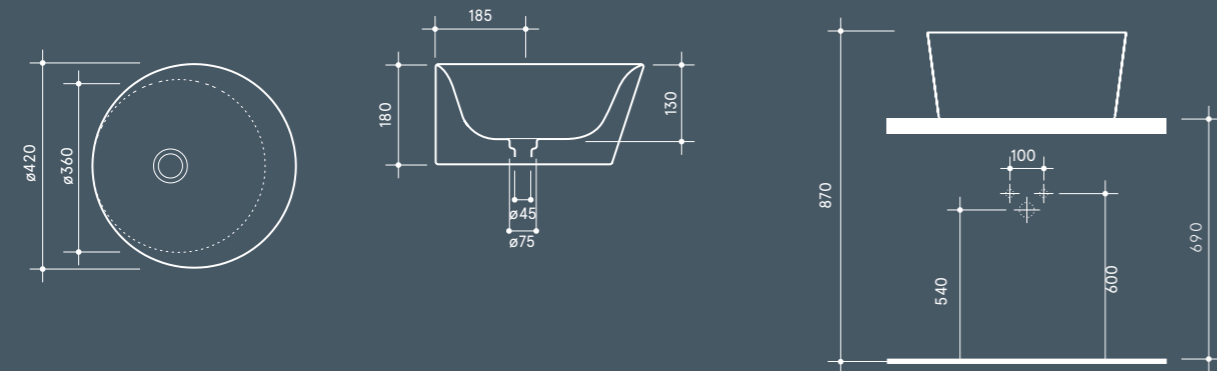

SOUL 55 X 38 H4 • U

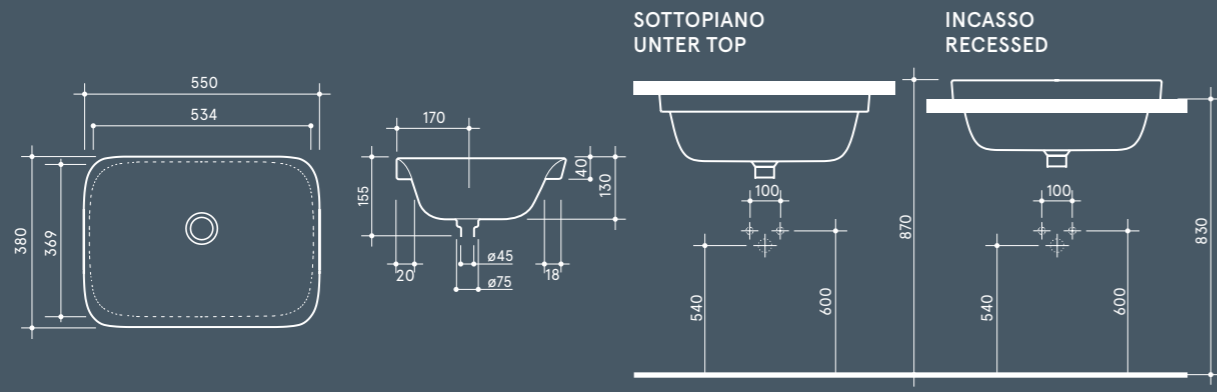

SOUL 55 X 38 H4 • U

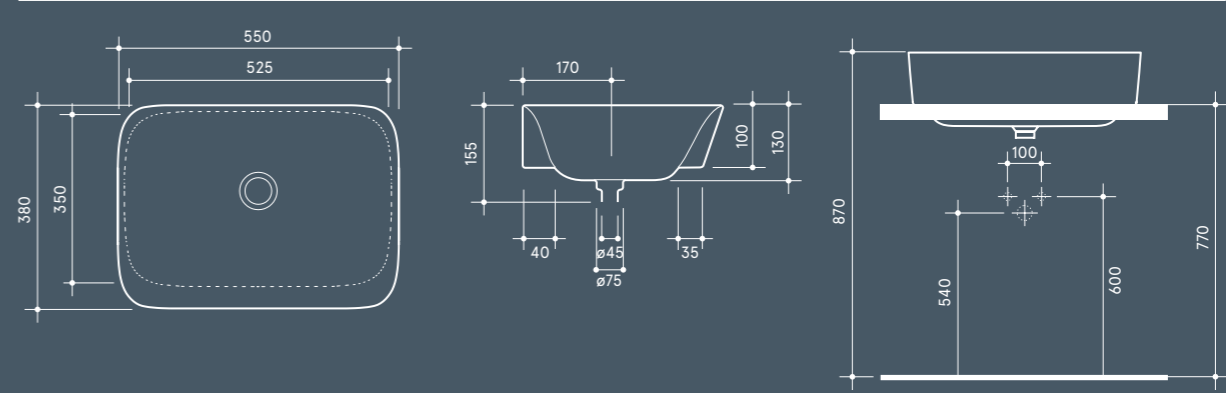

SOUL 55 X 38 H10

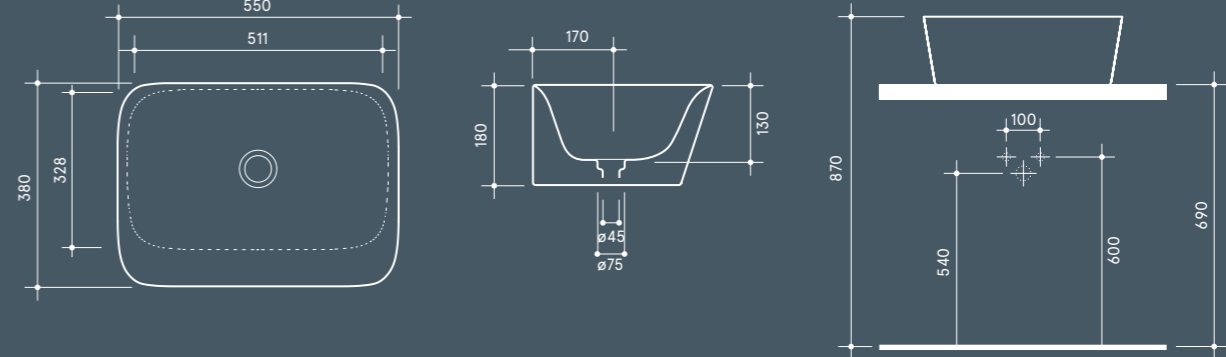

SOUL 55 X 38 H18

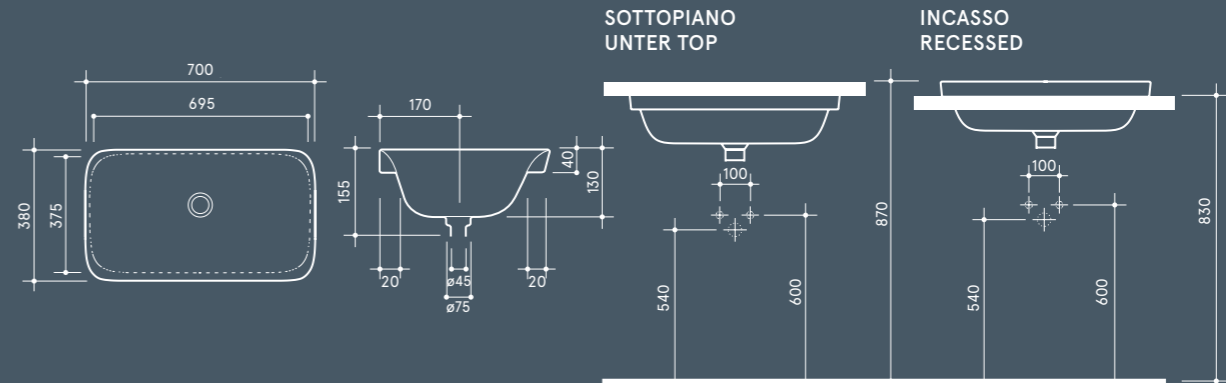

SOUL 70 X 38 H4 • U

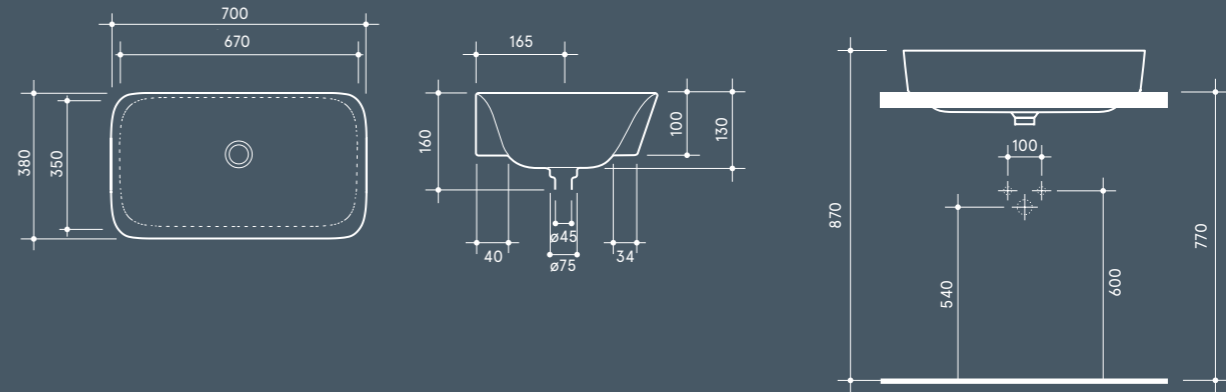

SOUL 70 X 38 H18

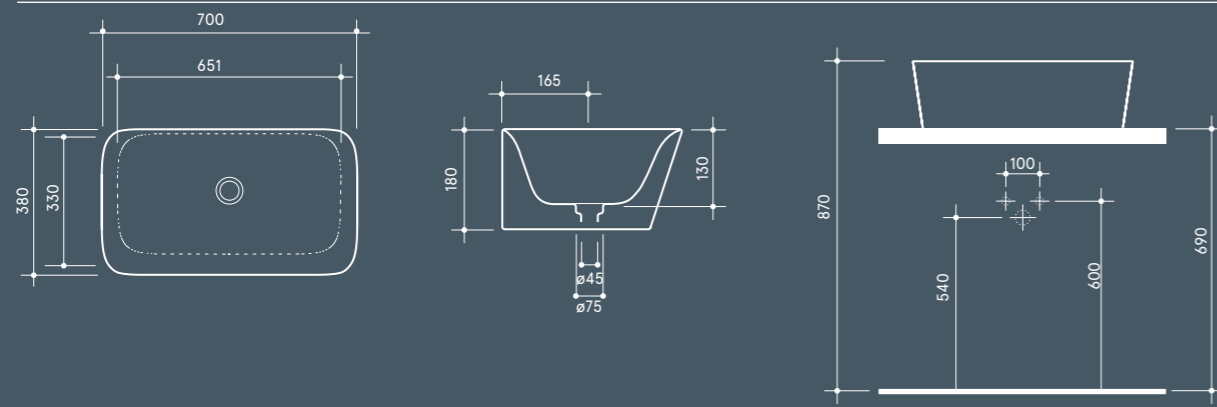

SOUL 55 X 42 H4

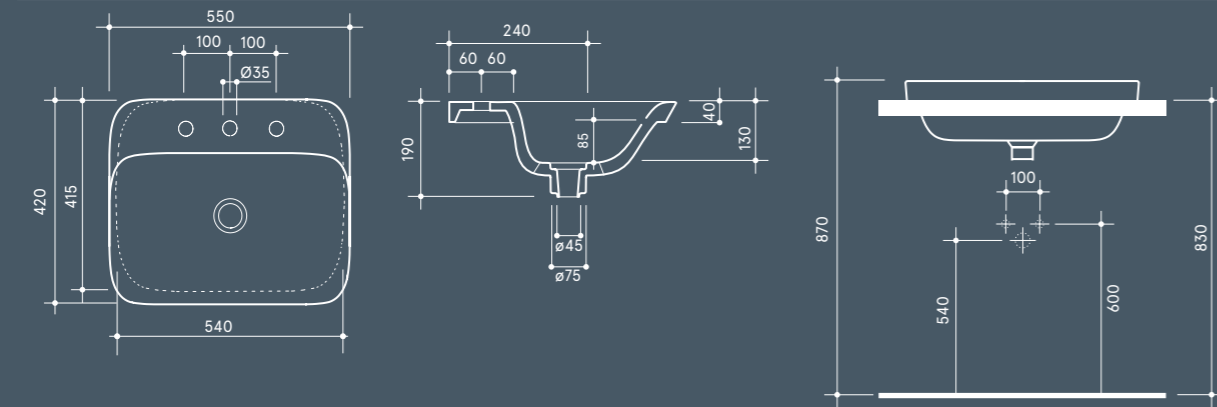

SOUL 55 X 42 H10

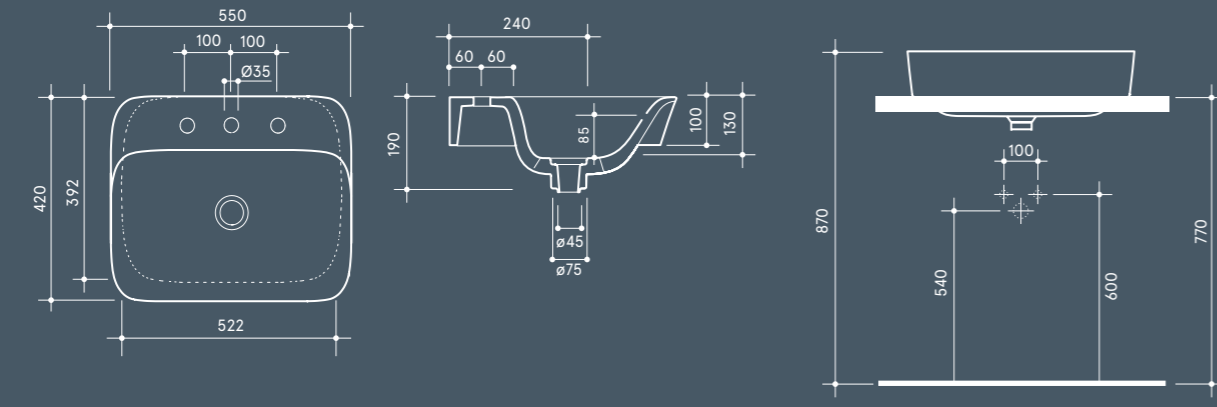

SOUL 55 X 42 H18

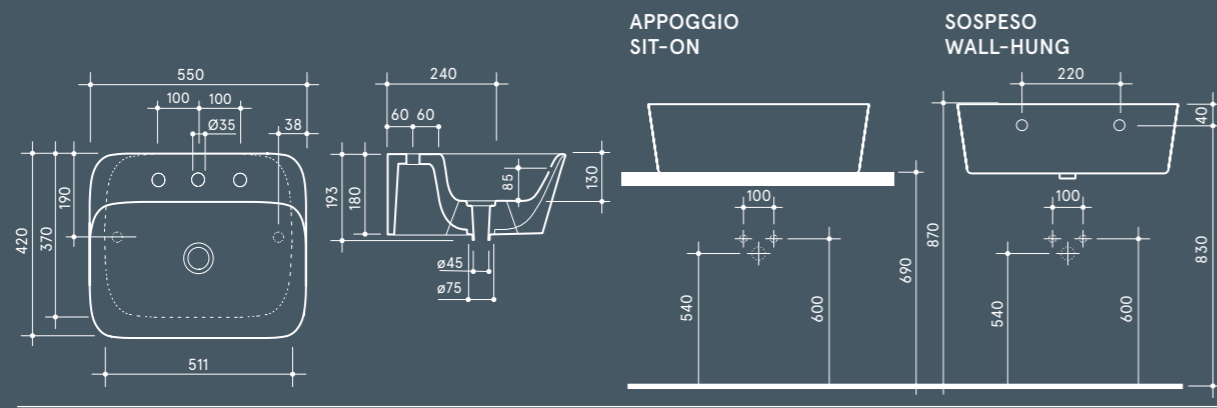

SOUL 70 X 42 H4

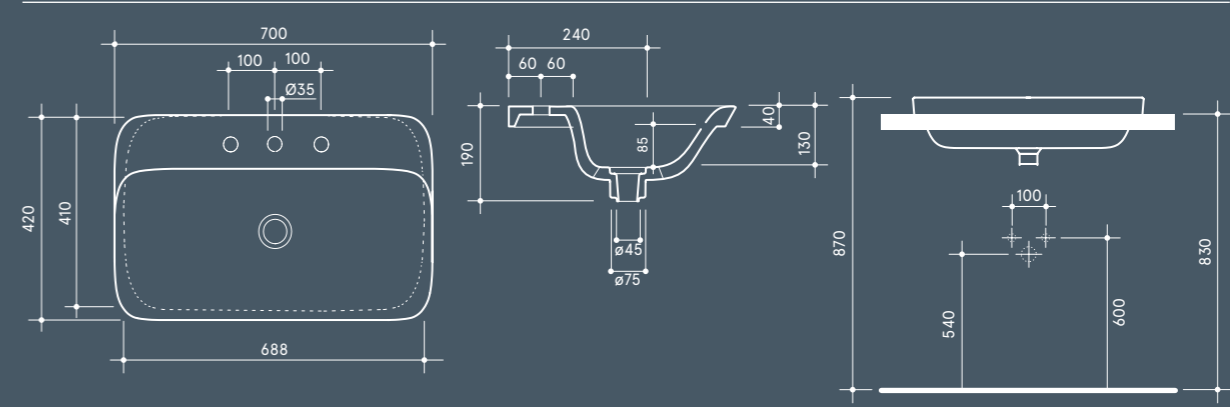

SOUL 70 X 42 H10

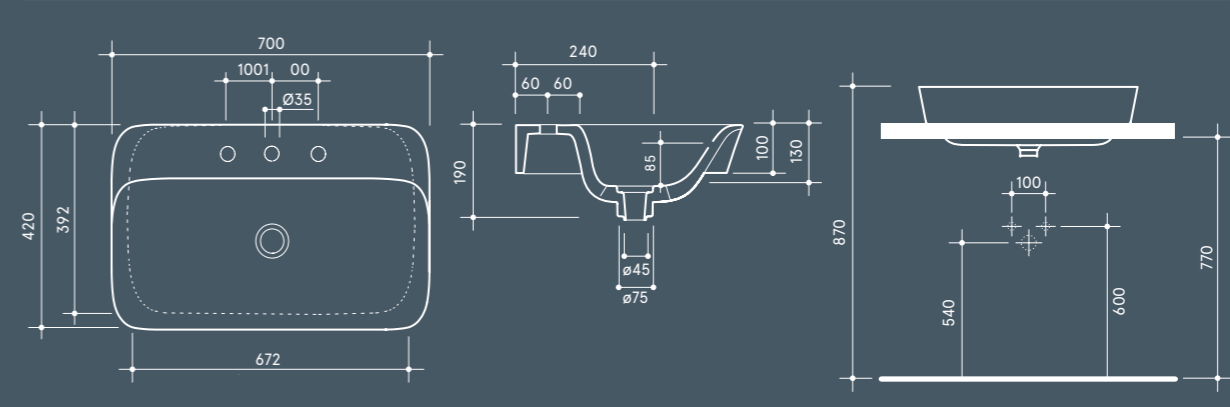

SOUL 70 X 42 H18

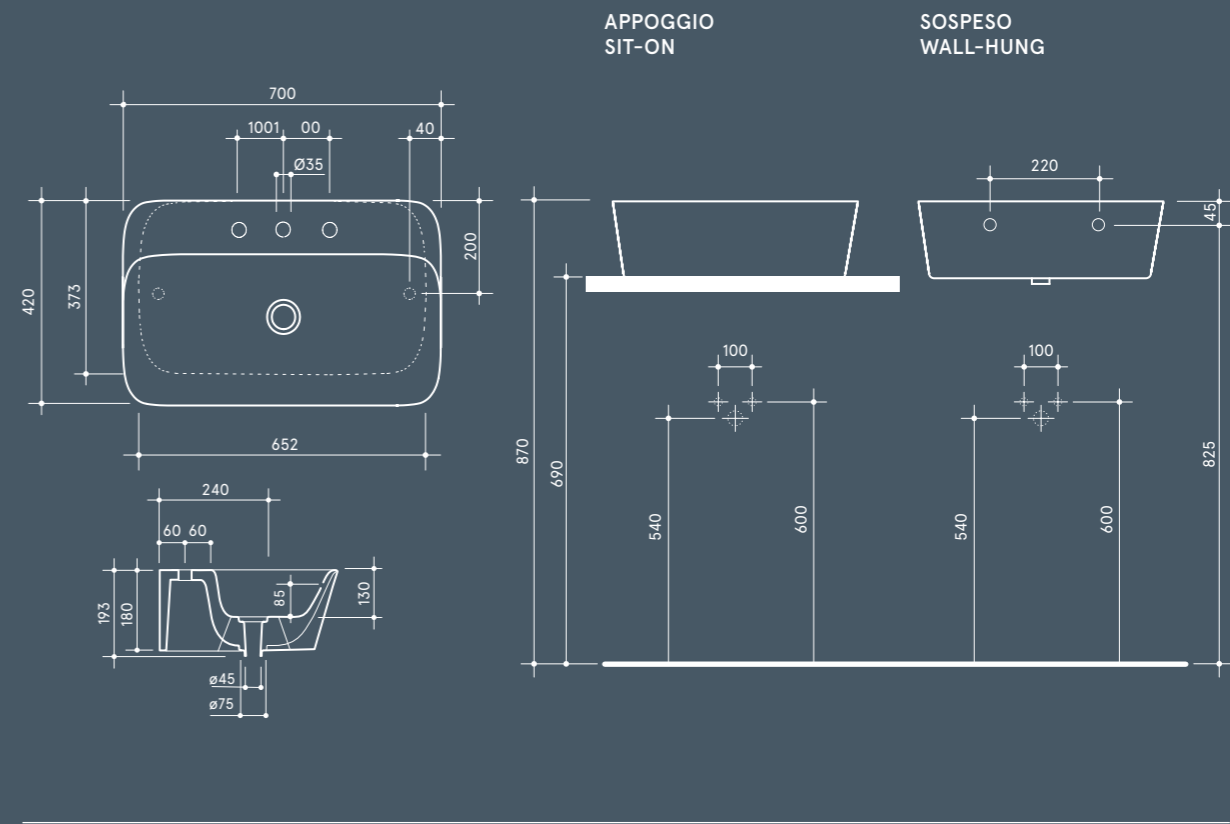

DESIGN
· MONIA MARZANO ·

START

•

UN'IDEA DI DESIGN
CHE CONIUGA LA FUNZIONALITÀ
AL RIGORE ESPRESSIVO

A PERFECT BLEND OF DESIGN COMBINING FLUID SHAPES
WITH FUNCTIONALITY

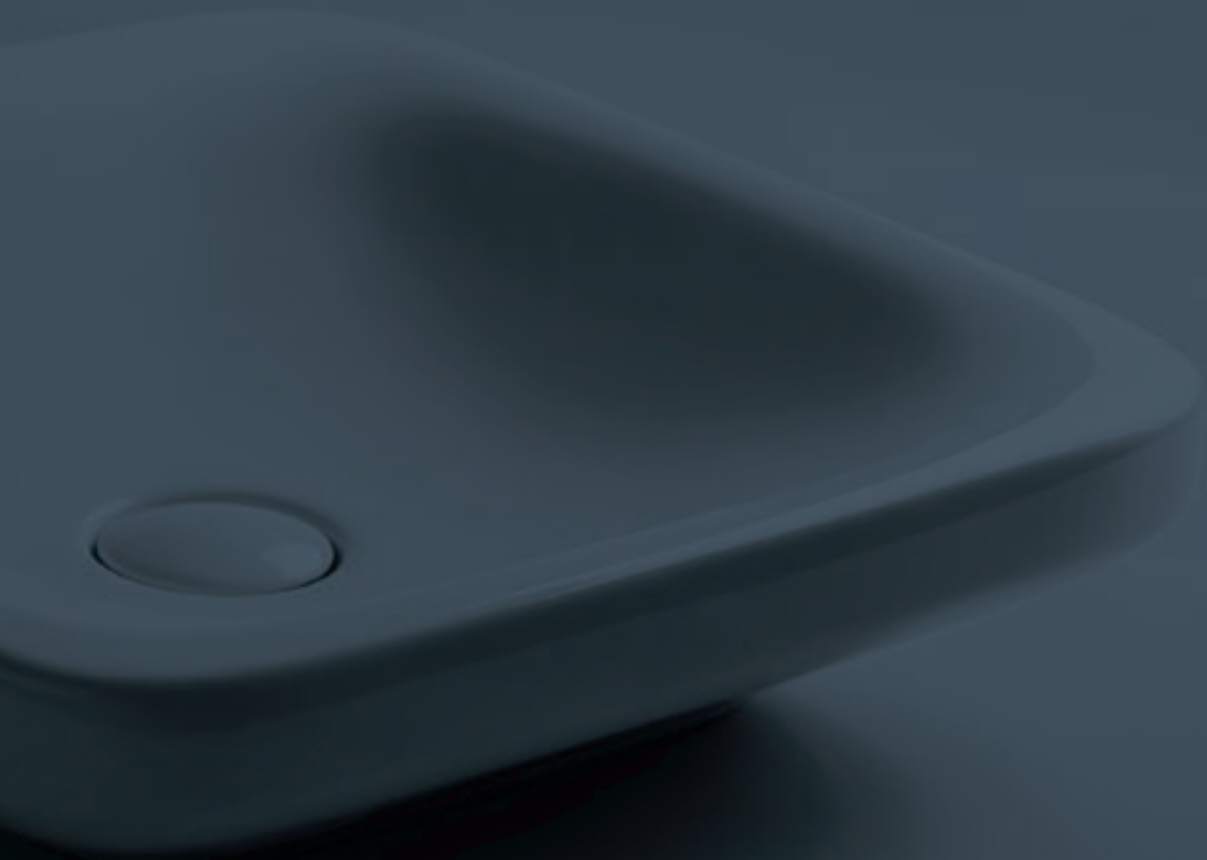

START COLLECTION

E' L'INCONTRO TRA MEMORIA E CONTEMPORANEO
CHE SI FONDONO IN MODO ARMONIOSO
NELLE FORME CARATTERIZZATE DA LINEE FLUIDE ED ESSENZIALI.

FORME ISPIRATE DAL CAMMINO DELL'ACQUA CHE SCORRE
SENZA INCONTRARE OSTACOLI. FORME ESALTATE
DALL'INTERAZIONE CHE SI CREA TRA LA LUCE E L'ACQUA
CHE SCIVOLA VERSO LA SINUOSITÀ DELLA BUCA.

POETICA DELLA SEMPLICITÀ:
OVVERO POETICA DELLA REALTÀ E DELLA CONCRETEZZA,
DELLA BELLEZZA ESSENZIALE. UN'IDEA DI DESIGN
CHE CONIUGA LA FUNZIONALITÀ AL RIGORE ESPRESSIVO.

.

IS THE FUSION BETWEEN MEMORY AND CONTEMPORARY
THAT HARMONIOUSLY MELT IN SHAPES
CHARACTERIZED BY FLUID AND ESSENTIAL LINES.

SHAPES INSPIRED BY THE WATER FLOWING
THAT GOES INCESSANTLY WITHOUT FACING ANY OBSTACLE.
SHAPES ENHANCED BY THE INTERACTION CREATED BETWEEN LIGHT
AND WATER FLOWING TOWARDS THE SINUOUS DRAIN.

POETRY OF SIMPLICITY:
POETRY OF REALITY AND CONCRETENESS, ESSENTIAL BEAUTY.
AN IDEA OF DESIGN THAT COMBINES FUNCTIONALITY WITH
EXPRESSIVE RIGOUR.



45 x45 x h12 cm

•

Appoggio
Sit-on





72 x 45 x h12 cm

•

Appoggio
Sit-on





50 x 50 x h12 cm



Sospeso
Wall-hung

Appoggio
Sit-on





72 x 50 x h12 cm

•

Sospeso
Wall-hung

Appoggio
Sit-on

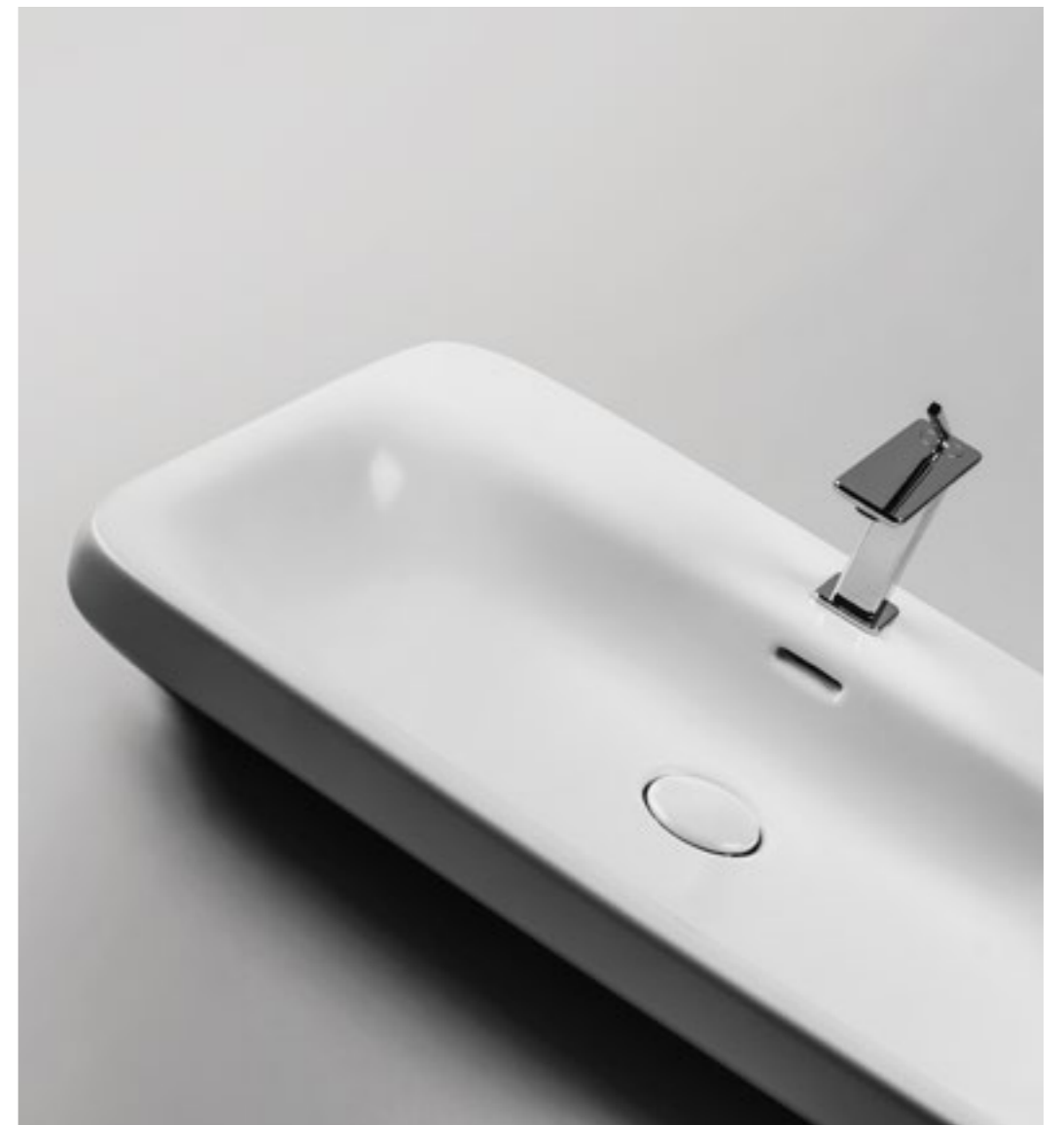

Freestanding
55 x 42 x h87 cm

•

A terra
Floor mounted

A parete/terra
Face wall



WC & Bidet
36 x 54 x h41 cm

•

Sospesi
Wall-hung





WC & Bidet
36 x 54 x h41 cm

•
A terra
Floor mounted

WC & Bidet
36 x 54 x h41 cm

•
Sospesi
Wall-hung





- 00 BIANCO LUCIDO
GLOSSY WHITE
- 01 BIANCO OPACO
MATT WHITE
- 02 NERO LUCIDO
GLOSSY BLACK
- 03 NERO OPACO
MATT BLACK

START 45 X 45 H12

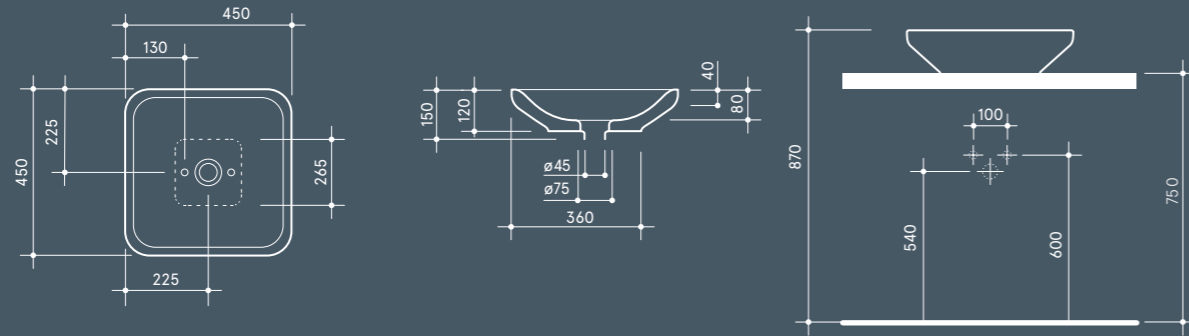

START 72 X 45 H12

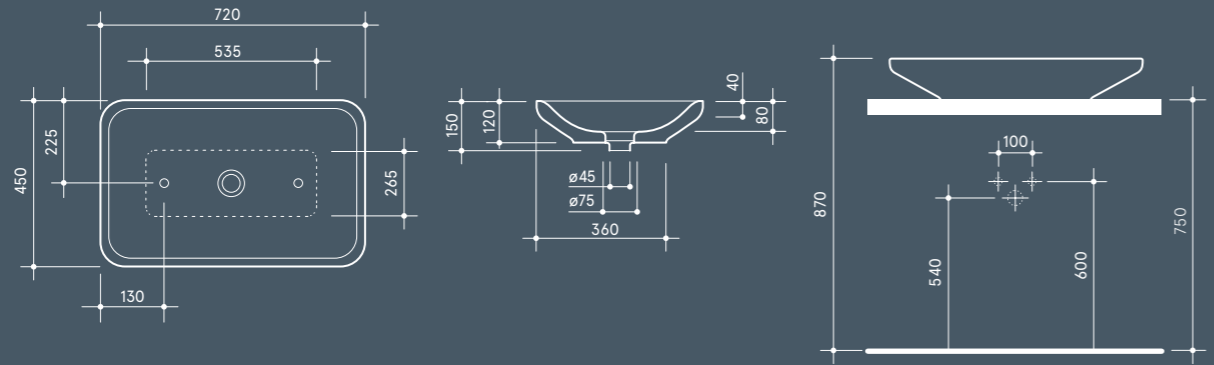

START 50 X 50 H12

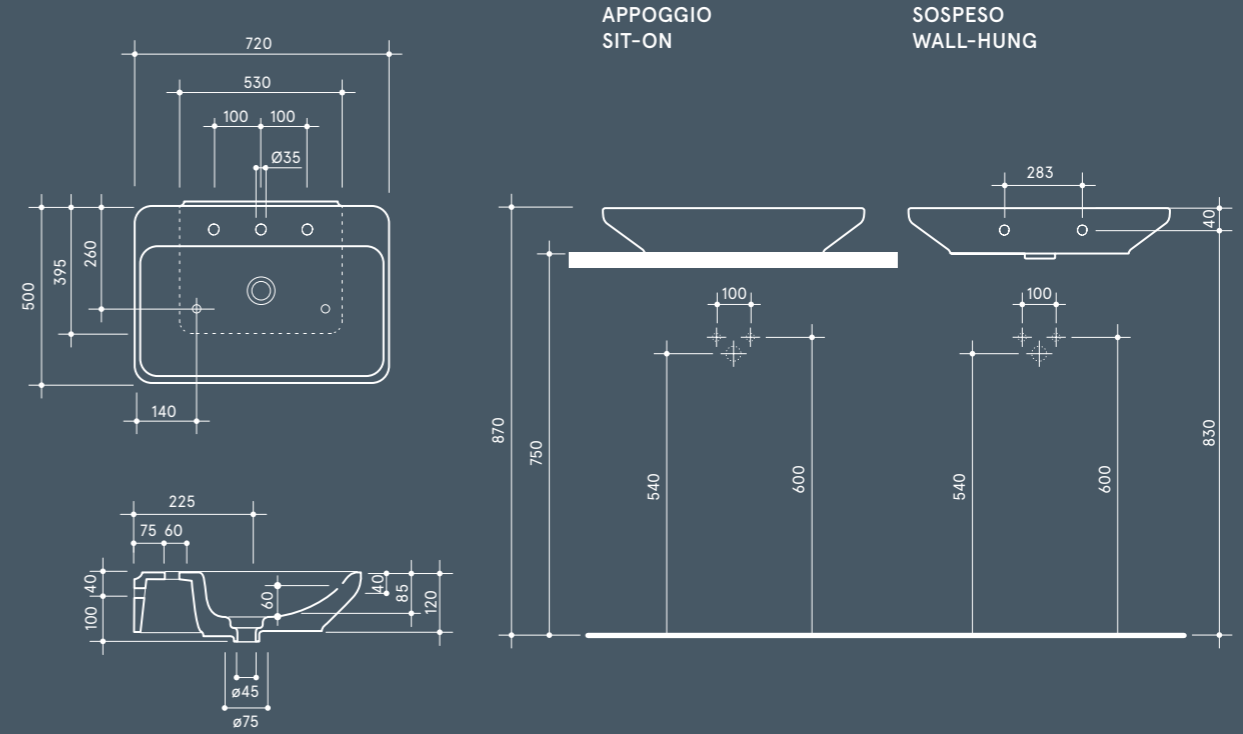
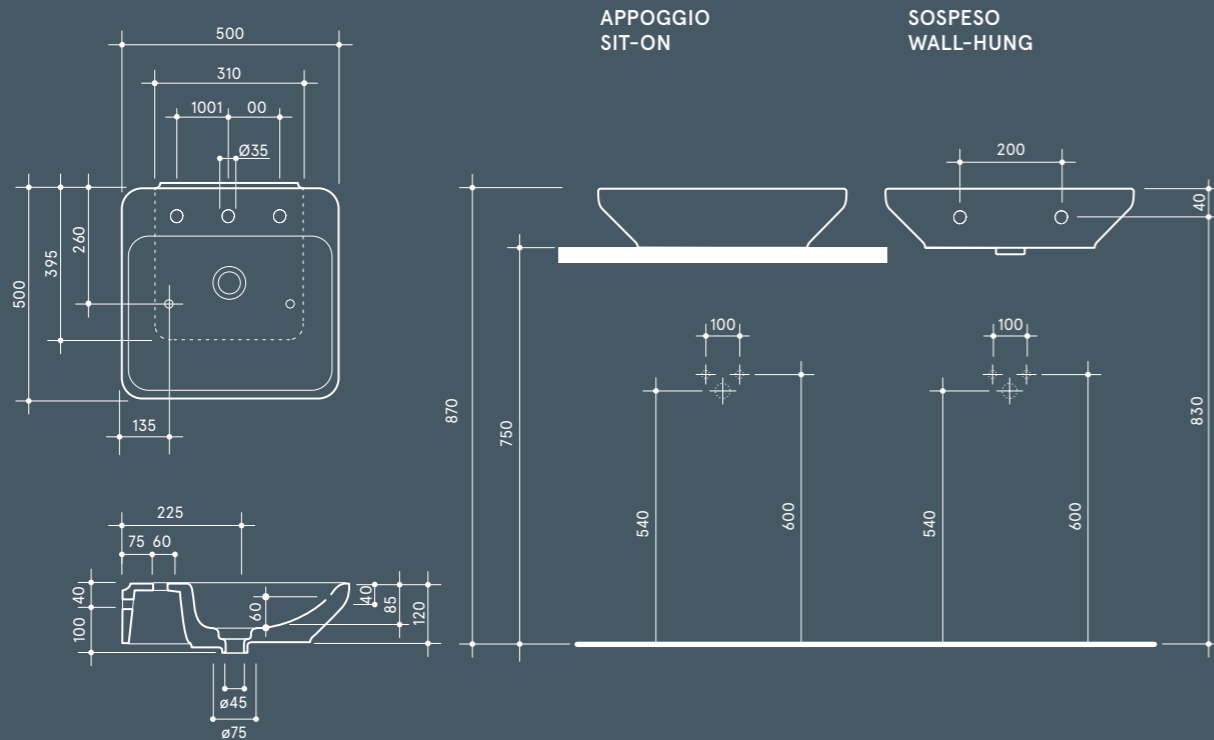

START 72 X 50 H12

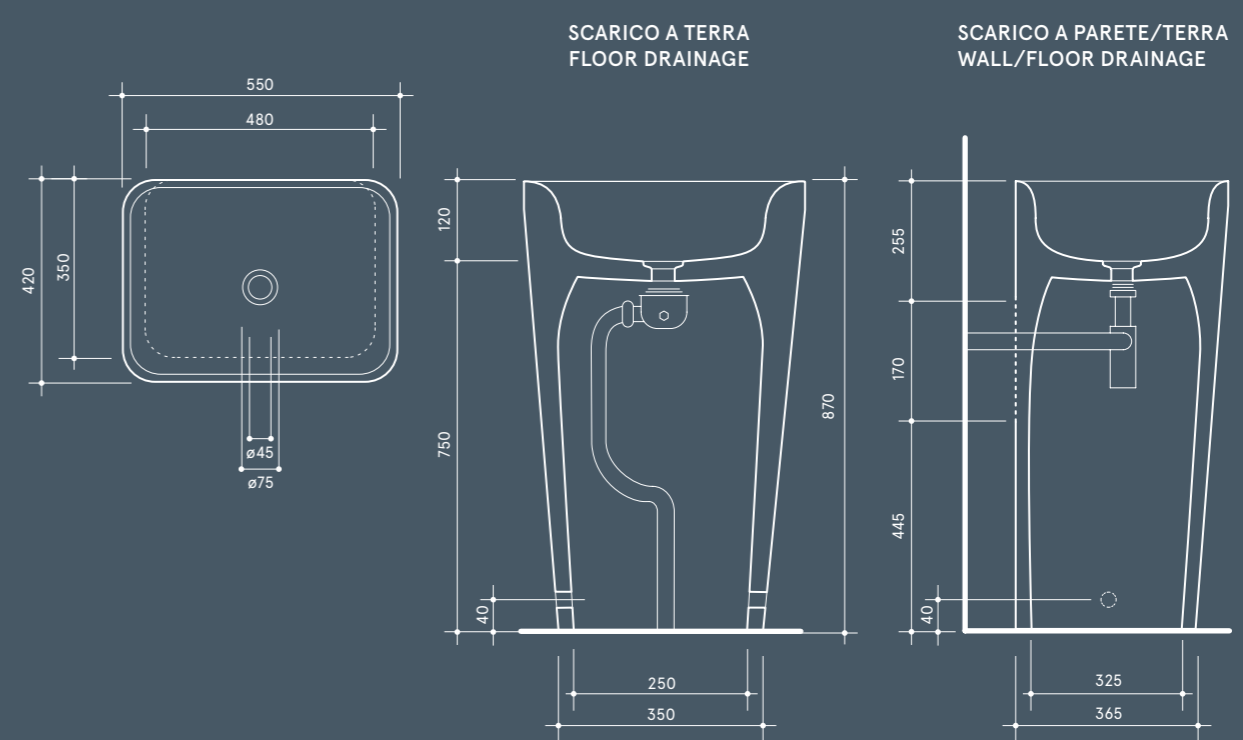

START FREESTANDING

START WC

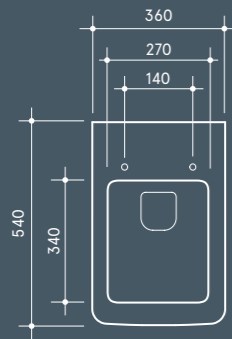

SOSPESO WALL-HUNG

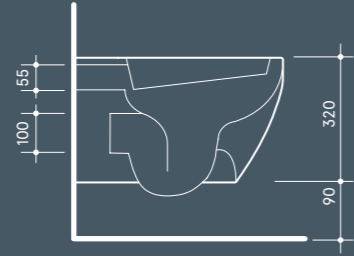

SOSPESO WALL-HUNG

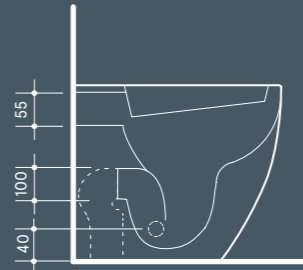
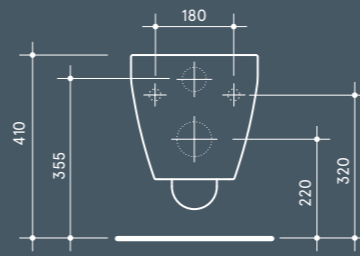

SCARICO A TERRA FLOOR MOUNTED

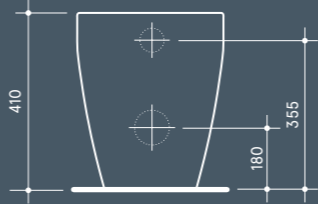

SCARICO A TERRA FLOOR MOUNTED

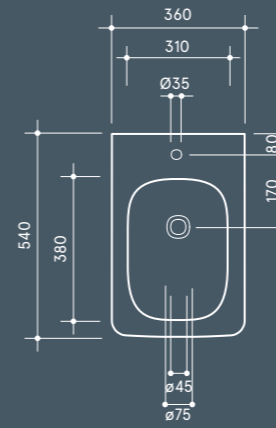

SOSPESO WALL-HUNG

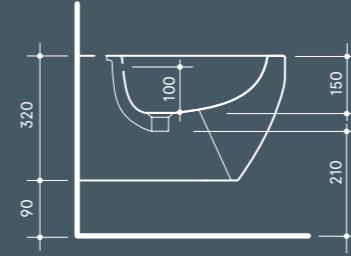

SCARICO A TERRA FLOOR MOUNTED

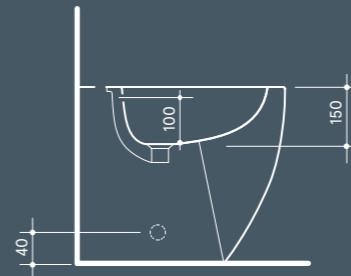

SOSPESO WALL-HUNG

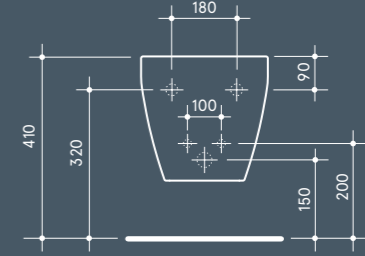

SCARICO A TERRA FLOOR MOUNTED

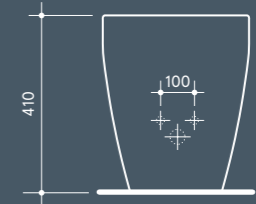

STAT BIDET

Art Direction

•

Prospero Rasulo

Photography

•

Antonio Rasulo

Thanks

•

Rubinetteria Gessi spa
Taps designed by
Prospero Rasulo
www.gessi.it

•

Print
TELLIGRAF srl

•

Printed in Italy
March 2017

Valdama srl

•

via Galileo Galilei, 5
01033 Civita Castellana
Viterbo, Italy

valdama.it
info@valdama.it

tel +39 0761 540709
+39 0761 540765
fax +39 0761 540499

Press Office

•

STUDIO UMBRELLA
pressoffice@umbrella.it
tel. +39 0422 305442
www.umbrella.it



